

PROPRIETARY AND CONFIDENTIAL

THE INFORMATION CONTAINED IN THIS DRAWING IS THE SOLE PROPERTY OF DYTRAN INSTRUMENTS INC. ANY REPRODUCTION IN PART OR AS A WHOLE WITHOUT THE WRITTEN PERMISSION OF DYTRAN INSTRUMENTS INC IS PROHIBITED.

REVISIONS

REV.	ECN	DESCRIPTION	BY/DATE	CHK	APPR
A	5112	INITIAL RELEASE	03/07/08	CES	PML

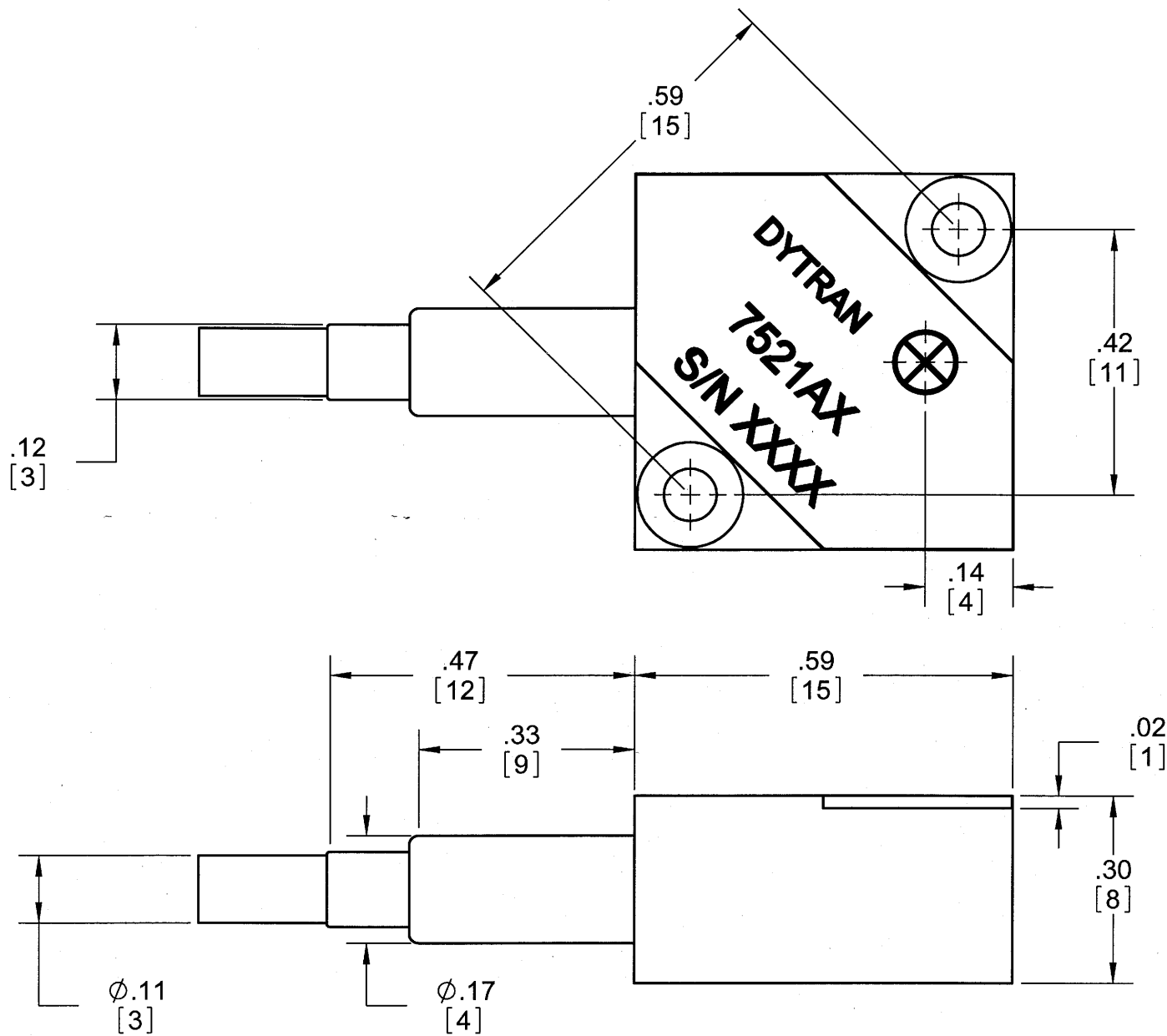

BLACK: -GRD
 RED: +EXCITATION
 GREEN: +SIGNAL
 WHITE: SELFTTEST

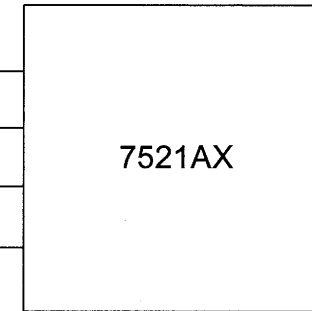

WIRING DIAGRAM

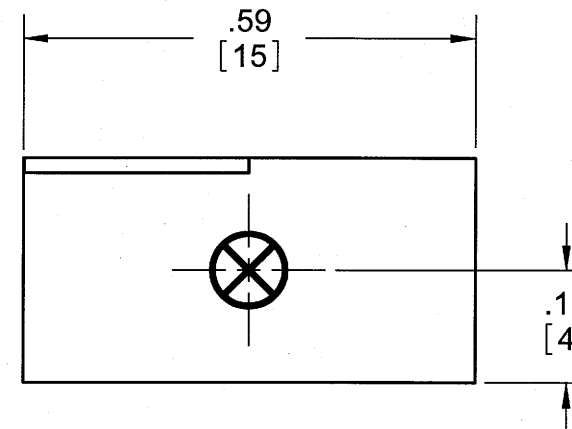

7521A1	550mV/g
7521A2	280mV/g
7521A3	93mV/g
7521A4	55mV/g
7521A5	36mV/g
7521A6	18mV/g
7521A7	8mV/g

DRILL HOLE SIZE	TOLERANCE	UNLESS OTHERWISE SPECIFIED: INTERPRET DIM & TOL PER ASME Y14.5M - 1994. REMOVE BURRS. COUNTERSINK INTERNAL THDS 90° TO MAJOR DIA. CHAM EXT THDS 45° TO MINOR DIA. THD LENGTHS AND DEPTHS ARE FOR MIN FULL THDS. THDS PER MIL-S-7742. DIMENSIONS APPLY AFTER FINISHING
.0135 THRU .125	+0.004 / -.001	
.1260 THRU .250	+0.005 / -.001	
.2510 THRU .500	+0.006 / -.001	
.5010 THRU .750	+0.008 / -.001	
.7510 THRU 1.000	+0.010 / -.001	
1.001 THRU 2.000	+0.012 / -.001	

THIRD ANGLE PROJECTION
 USA

ALL MACHINED SURFACES.
 TOTAL RUNOUT WITHIN .005.
 BREAK SHARP EDGES .005 TO .010.
 MACHINED FILLET RADII .005 TO .015.
 WELDING SYMBOLS PER AWS A2.4.
 ABBREVIATIONS PER MIL-STD-12.

UNLESS OTHERWISE SPECIFIED:
 DIMENSIONS ARE IN INCHES.
 TOLERANCES ARE:
 DECIMALS .XX ± .010
 .XXX ± .005
 ANGLES ± 1°

CONTRACT NO.

APPROVALS		DATE
ORIG	PML	10/18/07
CHK	CES	3.14.08
APP	PML	3.14.08
APP		

MATERIAL:
 ALUMINUM ALLOY

FINISH:

DO NOT SCALE DRAWING



MASTER
 ONLY IF IN RED

TITLE: DC ACCELEROMETER, SINGLE AXIS			
SIZE B	CAGE CODE 2W033	DWG NO 127-7521A	REV A
SCALE: 4:1	SOLIDWORKS	SHEET 1 of 1	



SPECIFICATIONS, SERIES 7521A ACCELEROMETER

PERFORMANCE BY MODEL NUMBER

	<u>7521A1</u>	<u>7521A2</u>	<u>7521A3</u>	<u>7521A4</u>	<u>7521A5</u>	<u>7521A6</u>	<u>7521A7</u>	UNITS
Input Range	±2	±5	±15	±33	±50	±100	±225	g
Output, bias, ±10%	2.5	2.5	2.5	2.5	2.5	2.5	2.5	V
Output range	±1.1	±1.4	±1.4	±1.8	±1.8	±1.8	±1.8	V
Bandwidth	0-1500	0-1500	0-1500	0-400	0-400	0-400	0-400	Hz
Sensitivity	550	280	93	55	36	18	8	mV/g
Output Noise (typical)	0.4	0.25	0.32	3	3	10	15	mg/√Hz
Output Impedance	3500	3500	3500	500	500	500	500	Ω

PERFORMANCE FOR ALL MODEL NUMBERS

	MIN	NOM	MAX	UNITS
Maximum Mechanical Shock			4000	g peak
Resonance Frequency		5000		Hz
Transverse Sensitivity			2	%
Operating Temperature	-55		+125	°C
Compensated Temperature Range (CTR)	-20		+70	°C
Thermal Zero			0.03	% FS/°C
Thermal Sensitivity Drift			0.02	% FS/°C
Storage Temperature	-55		+150	°C
Non-Linearity			0.3	%
Excitation, regulated		4.8-5.2		VDC
Current consumption, nom		0.4		mA

PHYSICAL PARAMETERS FOR ALL MODEL NUMBERS

Case Material		anodized aluminum		
Cable Length		79		inch
Mounting Provision		two M2 screws (provided)		
	MIN	NOM	MAX	UNITS
Case Length		0.59		inch
Case Width		0.59		inch
Case Height		0.30		inch
Mounting Hole Spacing		0.59		inch
Mass			3.7	grams

NOTES:

SUPPLIED ACCESSORIES:

(2) Mounting Screws (Model 6722), M2 x 12 flathead