

**FEATURES**

- Embedded EEPROM-based Calibration Data
- Digital Sensor Compensation
  - Up to  $\pm 0.05\%$  FS Static Accuracy
  - Up to  $\pm 0.005\%/^{\circ}\text{C}$  Thermal Stability
- Pressure ranges: 0-5 psi (34 kPa) to 0-10000 psi (69 Mpa)
- Welded 316 SS Construction



**APPLICATIONS**

- Turbomachinery Test Stands
- Hydraulic/Pneumatic Systems
- Process Control
- Environmental Monitoring

Series 9400 are highly accurate, digitally compensated pressure transducers designed specifically for use with PSI's Model 9021 or 9022 All-Media Intelligent Pressure Scanners in applications requiring compatibility with liquid and high-pressure media. The 9400 utilizes a highly accurate pressure sensor assembly specifically designed for hostile fluids and gases. The assembly is integrated with supporting electronics in a durable waterproof housing constructed of 316 SS. Standard pressure ranges are available from 0-5 to 0-10,000 psi in gage, absolute and differential reference pressure formats.

Series 9400 transducers achieve high accuracy and thermal stability through the use of digital compensation technology to correct zero, span, and linearity errors over the operating pressure and temperature range. Each digitally compensated transducer contains an integral serial EEPROM storing factory generated calibration data. This data is uploaded into the Model 9021 or 9022 Intelligent Pressure Scanners upon power-up and used to compensate for the inherent transducer errors during use. Static accuracy of up to  $\pm 0.05\%$  FS with thermal stability up to  $\pm 0.005\%/^{\circ}\text{C}$  are achieved using this technique. The Model 9021 and 9022 scanners support output pressure measurements from the 9400 transducers in engineering units over an Ethernet interface using TCP or UDP protocols.

The Series 9400 All-Media Pressure Transducer is one component of the NetScanner™ System. Multiple NetScanner components measuring a variety of parameters and sharing the same command set can be networked to form a distributed intelligent data acquisition system.

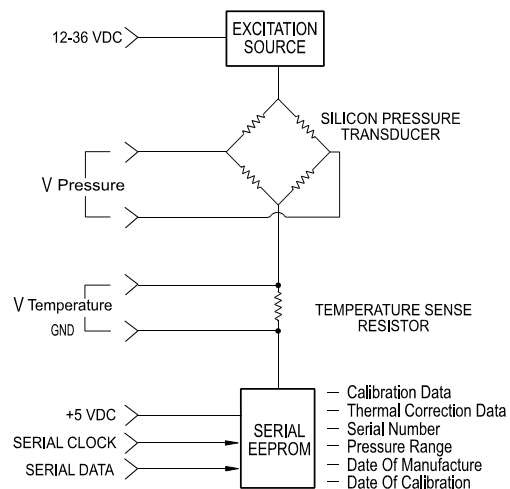

# Series 9400

# Specifications

After 1 hour warmup @ 25°C unless otherwise stated, FS = Full Scale

Parameter	9400	9401	9402	Units	Comments
<b>PNEUMATICS</b>					
<b>Pressure Reference</b>	Gage <sup>1</sup>	Absolute	Differential		
<b>Pressure Ranges</b>	5 (34) 10 (69) 15 (103) 50 (345) 100 (689) 250 (1724) 500 (3447) 750 (5171) 1000 (6895) 1500 (10342) 3000 (20684) 5000 (34474) 10000 (68947)	15 (103) 30 (207) 50 (345) 100 (689) 250 (1724) 500 (3447) 750 (5171) 1000 (6895) 1500 (10342) 3000 (20684) 5000 (34474) 10000 (68947)	5 (34) 10 (69) 15 (103) 50 (345) 100 (689) 250 (1724)	psi (kPa)	contact factory for other ranges
<b>Proof Pressure<sup>2</sup></b>		3.0 1.5		x FS	range ≤ 100 psi (689 kPa) range > 100 psi (689 kPa)
<b>Burst Pressure</b>		5x 3x 2x		x FS	range = 5 - 500 psi range >500 - 3000 psi range >3000 psi
<b>STATIC PERFORMANCE</b>					
<b>Static Accuracy<sup>3</sup></b>		±0.05 ±0.25 ±0.50		±0.5 N/A N/A	% FS % FS % FS range <750 psi range > 750 psi to ≤ 3000 psi range >3000 psi
<b>Total Thermal Error<sup>4</sup></b>				±0.005 ±0.05	% FS/°C % FS/°C digital compensation <sup>6</sup> analog compensation <sup>7</sup>
<b>Thermal Hysteresis</b>				±0.2	% FS after cycling over full temp range
<b>Max Line Pressure</b>		N/A	1000 (6885)	psi (kPa)	
<b>Line Pressure Effect<sup>5</sup></b>		N/A	±0.01	% FS/psi	
<b>ENVIRONMENTAL</b>					
<b>Wetted Materials</b>		316 SS & Viton			
<b>Compensated Temp Range</b>		0 to 50 -30 to 40		°C	standard optional
<b>Operating Temp Range</b>		-30 to 100		°C	
<b>ELECTRICAL</b>					
<b>Excitation</b>		12-36		VDC	
<b>Power Supply Rejection</b>		±.001		%/VDC	
<b>Output</b> Vo Vt		0-4.9 3.0 - 4.0		VDC VDC	

**Notes:**

- Pressure ranges > 750 psi are "sealed" gage rather than "vented" gage.
- Maximum pressure which can be applied without causing calibration shift.
- Static accuracy includes the combined errors due to nonlinearity, hysteresis and nonrepeatability following a zero calibration of the sensor.
- Includes effects of zero and span relative to 25°C.
- Primarily zero offset.
- For digital compensation type transducers, the on-board EEPROM contains full operating range temperature and nonlinearity correction coefficients.
- For analog compensation type transducers, the on-board EEPROM contains room temperature (approx. 25°C) nonlinearity correction coefficients.

**Specifications subject to change without notice.**

**Presented By : A-Tech Instruments Ltd.**

After 1 hour warmup @ 25°C unless otherwise stated, FS = Full Scale

Parameter	9400	9401	9402	Units	Comments
<b>ELECTRICAL (cont'd)</b>					
Output Impedance $V_o$ $V_t$		1000 1000		Ohm Ohm	max max
Insulation Resistance		50		M Ohm	@ 50 VDC
<b>PHYSICAL/ENVIRONMENTAL</b>					
Acceleration		$\pm 0.02$ $\pm 0.01$		% FS/g % FS/g	range $\leq 15$ psi (103 kPa) range $\geq 30$ psi (207 kPa)
Vibration		$\pm 0.05$		% FS/g	30 g peak 10 Hz - 2kHz
Weight		6 (170)	17 (480)	oz (gm)	
Pressure Connection		1/4" NPT, Male AN4, Male G1/4, Male M14, Male	7/16" Female SAE o-ring Boss		
Electrical Connection Standard Optional		PTIH - 12-8P Bendix PVC Jacketed Cable			

**Specifications subject to change without notice.**

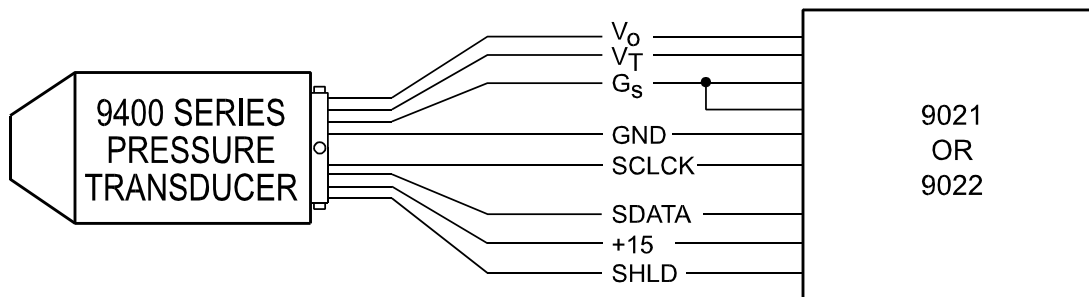

**INTERFACE CONNECTION TO 9021 OR 9022**

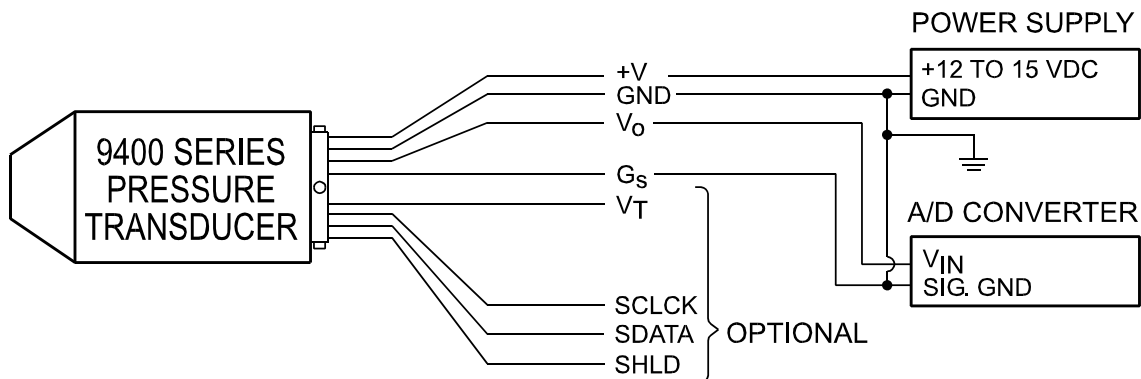

**INTERFACE TO CUSTOM DATA ACQUISITION SYSTEM**



**Presented By : A-Tech Instruments Ltd.**

# Series 9400 Ordering/Part Number Information

## Ordering Information:

PN: **9400-AAAABBC00E** 9400 All-Media Gage Pressure Transducer  
 PN: **9401-AAAABBC00E** 9401 All-Media Absolute Pressure Transducer

### AAAA = Pressure Range

0005, 0-5 psi (34 kPa)	0100, 0-100 psi (689 kPa)	1500, 0-1500 psi (10342 kPa)
0010, 0-10 psi (69 kPa)	0150, 0-150 psi (1034 kPa)	2000, 0-2000 psi (13789 kPa)
0015, 0-15 psi (103 kPa)	0250, 0-250 psi (1724 kPa)	3000, 0-3000 psi (20684 kPa)
0030, 0-30 psi (207 kPa)	0500, 0-500 psi (3447 kPa)	5000, 0-5000 psi (34474 kPa)
0050, 0-50 psi (345 kPa)	0750, 0-750 psi (5171 kPa)	9999, 0-10000 psi (68947 kPa)
0075, 0-75 psi (517 kPa)	1000, 0-1000 psi (6895 kPa)	

### BB = Pressure Fitting

- 01, 1/4" Male NPT
- 02, AN4, Male
- 03, G 1/4, Male
- 05, M14, Male

### C = Electrical Connection

- 2, Bendix PTIH-12-8P
- 4, PVC Cable (for 9021)
- 6, PVC Cable (for 9022)

### E = Temperature Compensation

- 0, Digital only (0 to 50°C)
- 1, Analog only (0 to 50°C)
- 8, Analog only (-30 to 40°C)
- 9, Digital only (-30 to 40°C)

PN: **9402-AAAA04C00E** 9402 All-Media Differential Pressure Transducer

### AAAA = Pressure Range

0005, 0-5 psi (34 kPa)	0050, 0-50 psi (345 kPa)
0010, 0-10 psi (69 kPa)	0100, 0-100 psi (689 kPa)
0015, 0-15 psi (103 kPa)	0250, 0-250 psi (1724 kPa)
0050, 0-50 psi (345 kPa)	

### C = Electrical Connection

- 2, Bendix PTIH-12-8P
- 4, PVC Cable (for 9021)
- 6, PVC Cable (for 9022)

### E = Temperature

- 0, Digital only (0 to 50°C)
- 1, Analog only (0 to 50°C)
- 8, Analog only (-30 to 40°C)
- 9, Digital only (-30 to 40°C)

Example: **9400-0010012000**

**9400 All-Media Pressure Transducer, 10 psig, 1/4" NPT, Bendix Connector, 0-50°C Digital Compensation**

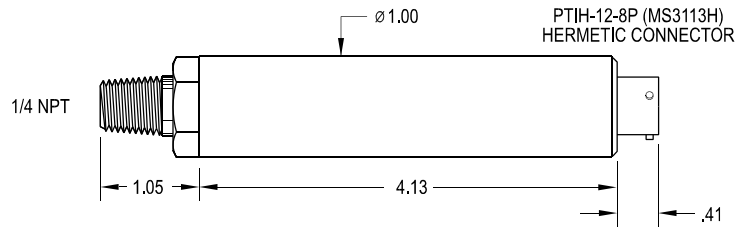
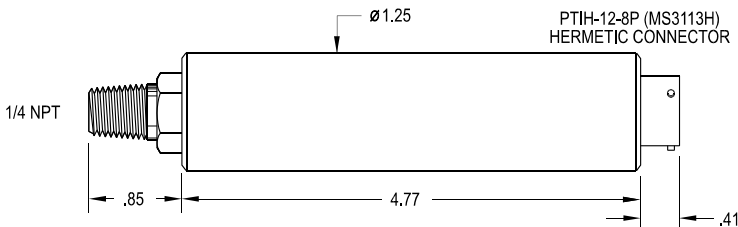

**9400 or 9401 > 750 psi**

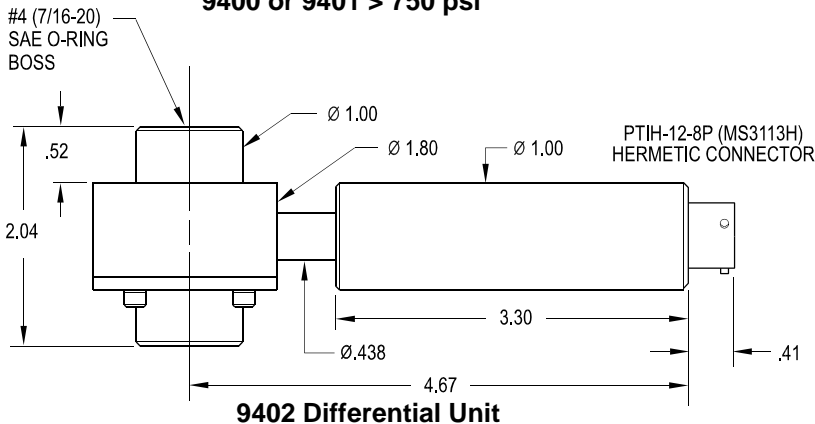

**9400 or 9401 ≤ 750 psi**

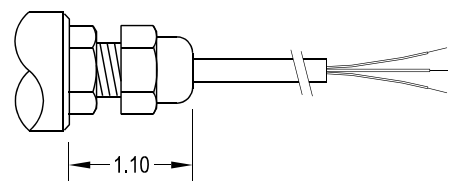

**Strain Relief with Cable  
(Length to be specified)**