

Rotierender Drehmomentsensor (Schleifring)
rotation torque sensor (slipring)

Typ DR-12

- Mit integrierter Drehwinkelmessung
- Mit Innen- und Außenvierkant
- integrated angle control
- both side with square end



Messbereich <i>nominal torque</i> [Nm]	Vier- kant <i>square</i>	Nenn- kennwert <i>sensitivity</i> [mV/V]	max. Dauer- drehzahl <i>cont. max speed</i> [min ⁻¹]	Feder- konstante <i>spring rate</i> [Nm/rad]	max Querlast [N] <i>max lateral load</i>	Massen- trägheitsmoment <i>moment of inertia</i> J in [kg m ²] Antriebsseite <i>drive side</i>	Gewicht <i>weight</i> [kg]
1	1/4"	0,5	2000	1,4·10 ²	4	3,2·10 ⁻⁶	0,5
2	1/4"	0,5	2000	4,5·10 ²	5	3,3·10 ⁻⁶	0,5
5	1/4"	2	2000	3,0·10 ²	7	3,2·10 ⁻⁶	0,5
12	1/4"	2	2000	6,7·10 ²	7,5	3,3·10 ⁻⁶	0,5
25	3/8"	2	1500	2,4·10 ³	12	1,2·10 ⁻⁵	0,5
63	3/8"	2	1500	6,8·10 ³	28	1,2·10 ⁻⁵	0,5
160	1/2"	2	1500	1,2·10 ⁴	65	1,7·10 ⁻⁵	0,6
500	3/4"	2	1000	3,9·10 ⁴	200	9,2·10 ⁻⁵	1,3
1000	1"	2	1000	8,9·10 ⁴	240	3,6·10 ⁻⁴	1,5
2000	1 1/2"	2	500	3,6·10 ⁵	450	3,3·10 ⁻³	7,9
5000	1 1/2"	2	500	4,4·10 ⁵	500	3,4·10 ⁻³	8

Eine kurzzeitige Überschreitung der Maximaldrehzahl um Faktor 1,5 ist möglich
Grenzspezifikation: $t_{max} \leq 1 \text{ min}$ bei 50% ED
A short time overstep of the maximum speed is possible by a factor 1,5
worst case: $t_{max} \leq 1 \text{ min}$ at 50% on period.

Presented By : A-Tech Instruments Ltd.

Phone 416 754 7008 Fax 416 754 2351



Email: sales@tech.ca

Homepage: www.lorenz-messtechnik.de

Technische Änderungen vorbehalten
Technical modification to reserve

080090e_dr-12.doc
1/4

TECHNISCHE DATEN - specifications

TYP - type		DR-12
Genauigkeitsklasse - accuracy class	% v.E	0,1
Kennwerttoleranz - tolerance of sensitivity	%	±0,1
Reproduzierbarkeit n. DIN 1319 - nonrepeatability	%	±0,05
Speisespannung - excitation voltage	V	2 ... 12
max Speisespannung - max excitation voltage	V	15
Speisespannung Winkel - excitation voltage angle	v	5
Impulse / Umdrehung - Imp. / Rotation		360
Spuren 90° versetzt - channel 90° (quadrature)		2
Pegel - Signal	V	5 (TTL)
Rechtsdrehung - CW - turn		
CH A  CH B 		
Brückenwiderstand - bridge resistance	Ω	350
Nenntemp.bereich - nominal temp. range	°C	+5 ... +50
Gebrauchstemp.bereich - service temp. range	°C	-10 ... +60
Verdrillwinkel bei Nennmoment - twist angle by nominal load	°	<0,5
Grenzmoment (statisch) - limit torque	% v.E.	130
Gebrauchsmoment - service torque	% v.E.	120
Bruchmoment (statisch) - ultimate torque	% v.E.	250
Standzeit der Bürsten ca. - durability of brushes	Umdr.-rev.	5x10 ⁷
Schwingbreite (DIN 50100) - bandwidth	%	70 (Spitze - Spitze) - (top - top)
Schutzart - level of protection (DIN EN 60529)		IP 50
Anschlußstecker - connector		12 polig 12-pin

Anschlussbelegung - connection

12-polig 12-pin		
Pin A	Vers. (GND) DMS - excitation strain gauge	0V
Pin B	Vers. (+) DMS - excitation strain gauge	2...12 V
Pin C	Sign. (+) - signal	
Pin D	Sign. (-) - signal	
Pin E	Vers. Winkel - excitation angle	0V
Pin F	Vers. Winkel - excitation angle	+5V
Pin G	Winkel A (TTL) - angle A (TTL)	
Pin H	Winkel B (TTL) - angle B (TTL)	
Pin J	Winkel - angle	0V
Pin K	Kontrolle - calibration control	(Option - option)
Pin L	NC	
Pin M	Schirm - shield	

Mechanische Abmessungen – dimensions

DR-12

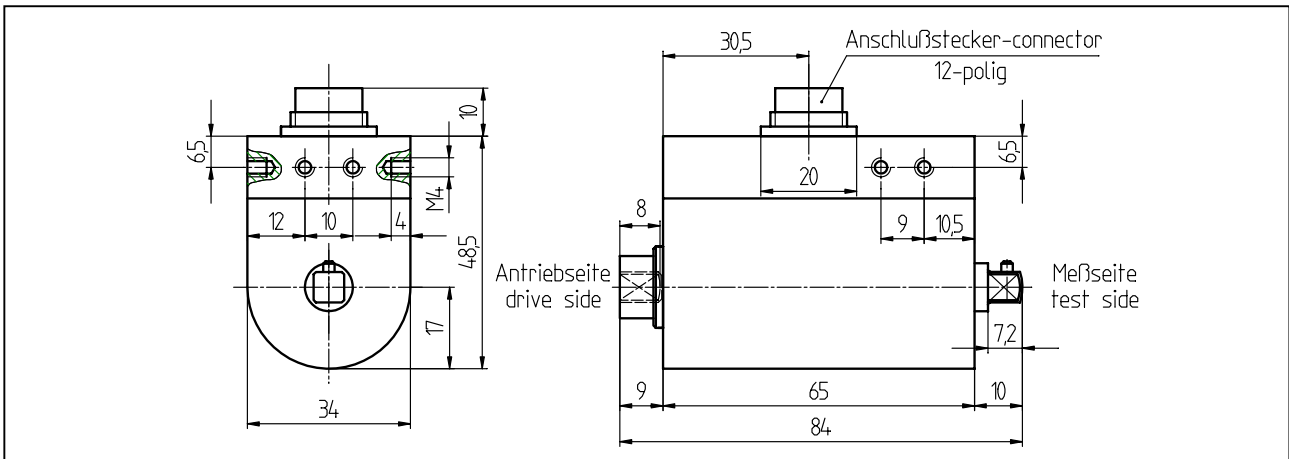

Messbereich - nominal torque [Nm]	Vierkant - square
0...12	1/4"

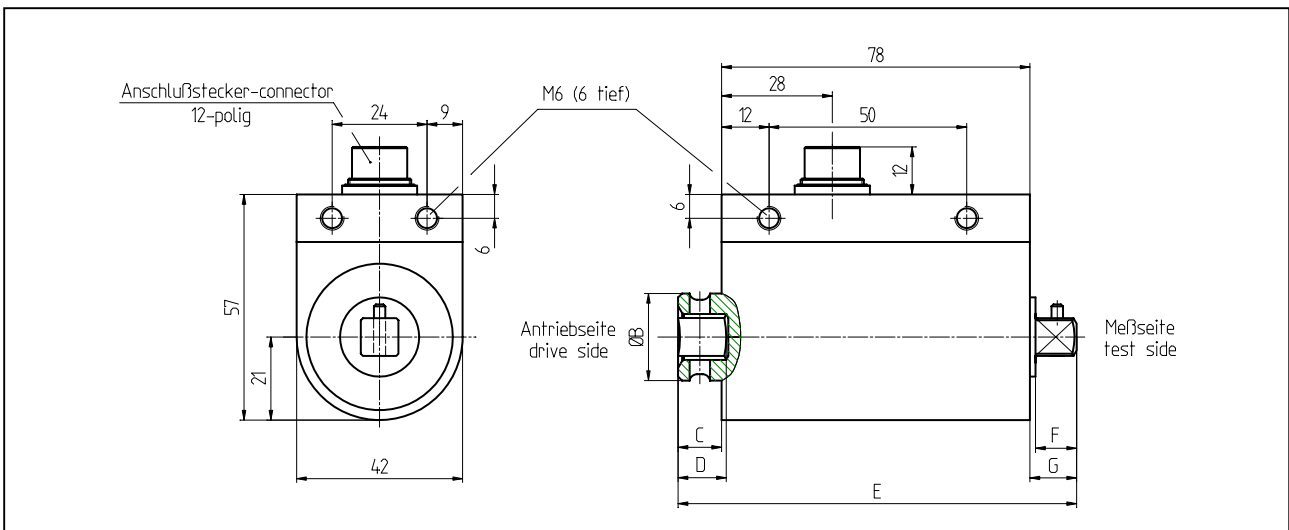

Messbereich nominal torque [Nm]	Vierkant square	Abmessungen - dimensions [mm]					
		B	C	D	E	F	G
0...63	3/8"	22	11	12,2	100,8	10,4	11,8
0...160	1/2"	29,8	12	16,9	106	15,1	16

Mechanische Abmessungen – dimensions

DR-12

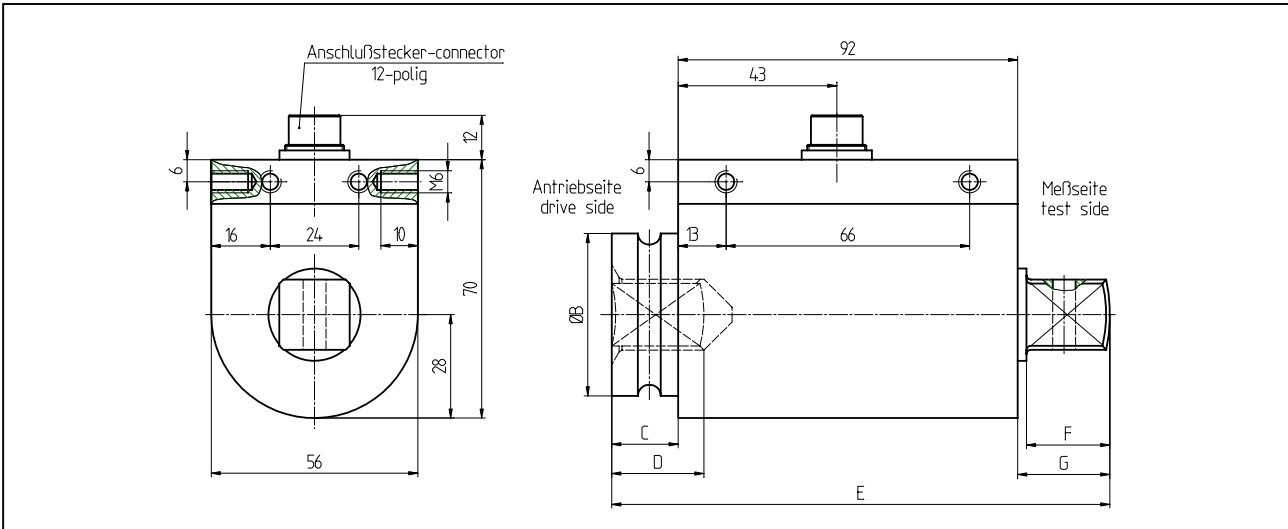

		Abmessungen - dimensions [mm]					
Messbereich nominal torque [Nm]	Vierkant square	B	C	D	E	F	G
0...500	3/4"	44	18	24,9	135	22,6	25
0...1000	1"	54	53,1	29,9	177	27,3	31,9

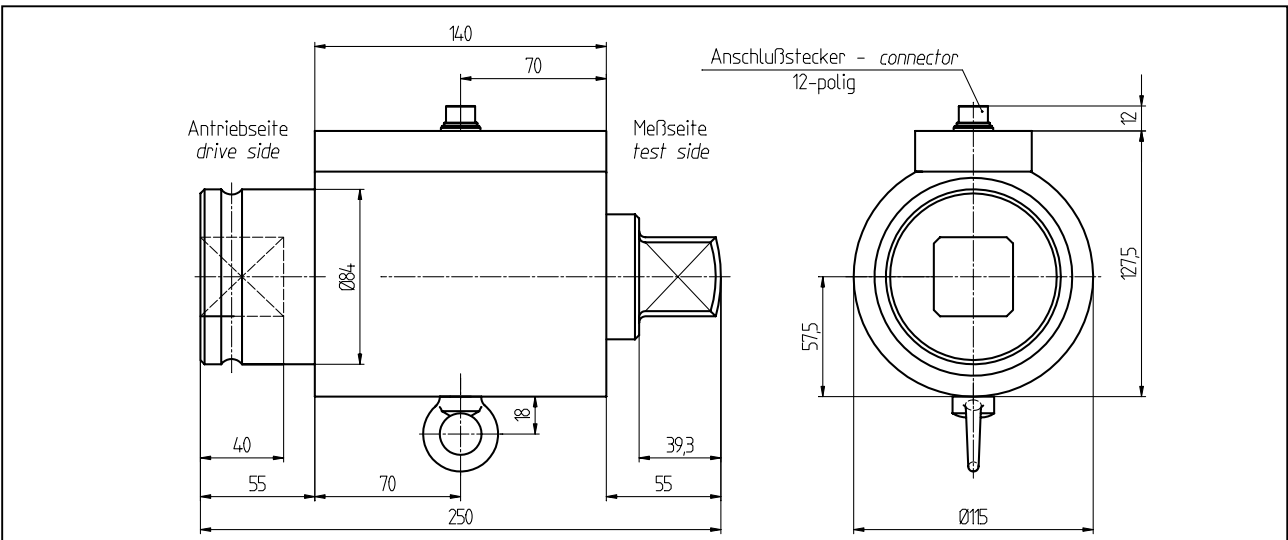

Messbereich - nominal torque [Nm]	Vierkant - square
0...5000	1 1/2"

Presented By : A-Tech Instruments Ltd.

Phone 416 754 7008 Fax 416 754 2351

Email: sales@a-tech.ca

Homepage: www.lorenz-messtechnik.de

Technische Änderungen vorbehalten
 Technical modification to reserve

080090e_dr-12.doc
 4/4