



MINIATURE HIGH PRESSURE IS® PRESSURE TRANSDUCER WITH INTEGRATED TEMPERATURE SENSOR

HKL/T-1-235 (M) SERIES

- World's Smallest Pressure and Temperature Sensor at 6mm
- Combined Pressure and Temperature Capability
- Patented Leadless Technology
- Robust Construction
- Excellent Long Term Stability
- Intrinsically Safe Patented Leadless Technology Applications Available (i.e. IS-HKL/T-1-235)



The HKL/T-1-235 (M) is a miniature threaded high pressure transducer/platinum RTD combination. The pressure transducer utilizes a patented silicon on silicon design. The platinum RTD protrudes beside the diaphragm to sense media temperature. The pressure and temperature devices are designed to operate independently. All wetted parts of the transducer are compatible with all common aircraft and automotive fluids.

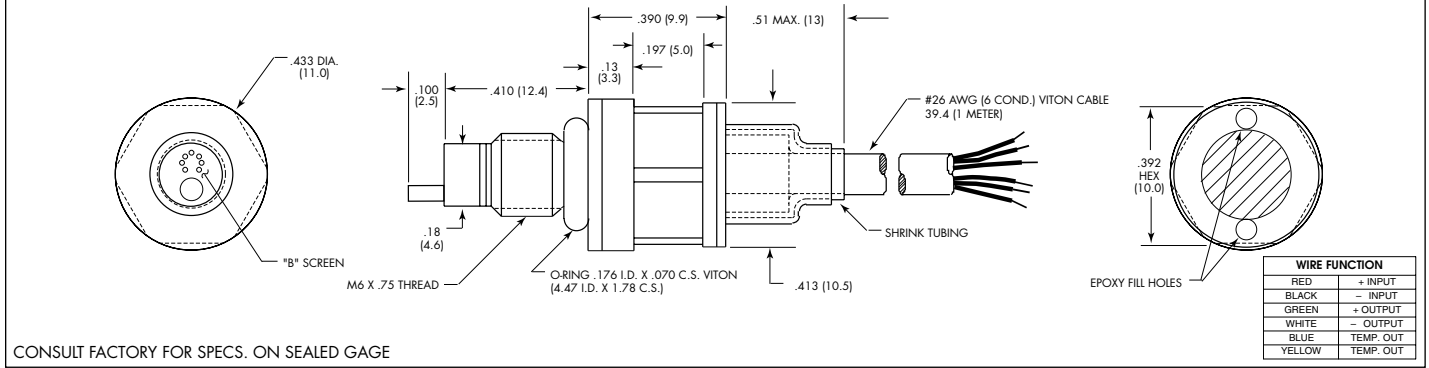

CONSULT FACTORY FOR SPECS. ON SEALED GAGE

INPUT	1.7	3.5	7	17	35	70	170	250 BAR
Pressure Range	25	50	100	250	500	1000	2500	3600 PSI
Operational Mode	Absolute, Gage, Sealed Gage, Differential			Absolute, Sealed Gage				
Over Pressure	2 Times Rated Pressure							
Burst Pressure	3 Times Rated Pressure							
Pressure Media	All Nonconductive, Noncorrosive Liquids or Gases (Most Conductive Liquids and Gases - Please Consult Factory)							
Rated Electrical Excitation	10 VDC							
Maximum Electrical Excitation	15 VDC							
Input Impedance	1000 Ohms (Min.)							
OUTPUT								
Output Impedance	1000 Ohms (Nom.)							
Full Scale Output (FSO)	100 mV (Nom.)							
Temperature Sensing RTD	1000 Ohms Platinum RTD							
Residual Unbalance	± 5 mV (Typ.)							
Combined Non-Linearity, Hysteresis and Repeatability	± 0.1% FSO BFSL (Typ.), ± 0.5% FSO (Max.)							
Resolution	Infinitesimal							
Natural Frequency (KHz) (Typ.)	240	300	380	550	7000	1000	1500	2000
Acceleration Sensitivity % FS/g	5.0x10 ⁻⁴	3.0x10 ⁻⁴	1.5x10 ⁻⁴	1.0x10 ⁻⁴	6.0x10 ⁻⁵	4.0x10 ⁻⁵	2.2x10 ⁻⁵	1.4x10 ⁻⁵
Perpendicular	6.0x10 ⁻⁵	4.0x10 ⁻⁵	2.0x10 ⁻⁵	9.0x10 ⁻⁶	6.0x10 ⁻⁶	3.0x10 ⁻⁶	2.2x10 ⁻⁶	1.4x10 ⁻⁶
Transverse	100 Megohm Min. @ 50 VDC							
Insulation Resistance								
ENVIRONMENTAL								
Operating Temperature Range	-65°F to +350°F (-55°C to +175°C)							
Compensated Temperature Range	80°F to +180°F (25°C to +80°C) Any 100°F Range Within The Operating Range on Request							
Thermal Zero Shift	± 1% FS/100°F (Typ.)				± 2% FS/100°F For 25 PSI Range			
Thermal Sensitivity Shift	± 1% FS/100°F (Typ.)				± 2% FS/100°F For 25 PSI Range			
Linear Vibration	100g Peak, Sine Up to 5000 Hz							
Humidity	100% Relative Humidity							
Mechanical Shock	20,000g, 100µ sec.							
PHYSICAL								
Electrical Connection	6 Conductor 26 AWG Viton Cable Without Shielding 1 Meter Long							
Weight	15 Grams (Max.) Excluding Cable							
Pressure Sensing Principle	Fully Active Four Arm Wheatstone Bridge Dielectrically Isolated Silicon on Silicon Patented Leadless Technology							
Mounting Torque	6 Nm ± 1 Nm							

Note: Custom pressure ranges, accuracies, mechanical configurations and RTD resistance available. Dimensions are in inches. Dimensions in parenthesis are in millimeters. Continuous development and refinement of our products may result in specification changes without notice - all dimensions nominal. (A)