



# MINIATURE IS® PRESSURE TRANSDUCER WITH INTEGRATED TEMPERATURE SENSOR

## HKL/T-375 (M) SERIES

- Combined Pressure and Temperature Capability
  - Robust Construction
  - Excellent Long Term Stability
  - Intrinsically Safe Patented Leadless Technology
- Applications Available (i.e. IS-HKL/T-375)



The HKL/T-375 (M) is a miniature threaded pressure transducer/platinum RTD combination. The pressure transducer utilizes a patented silicon on silicon design. The platinum RTD protrudes beside the diaphragm to sense media temperature. The pressure and temperature devices are designed to operate independently. All wetted parts of the transducer are compatible with all common aircraft and automotive fluids.

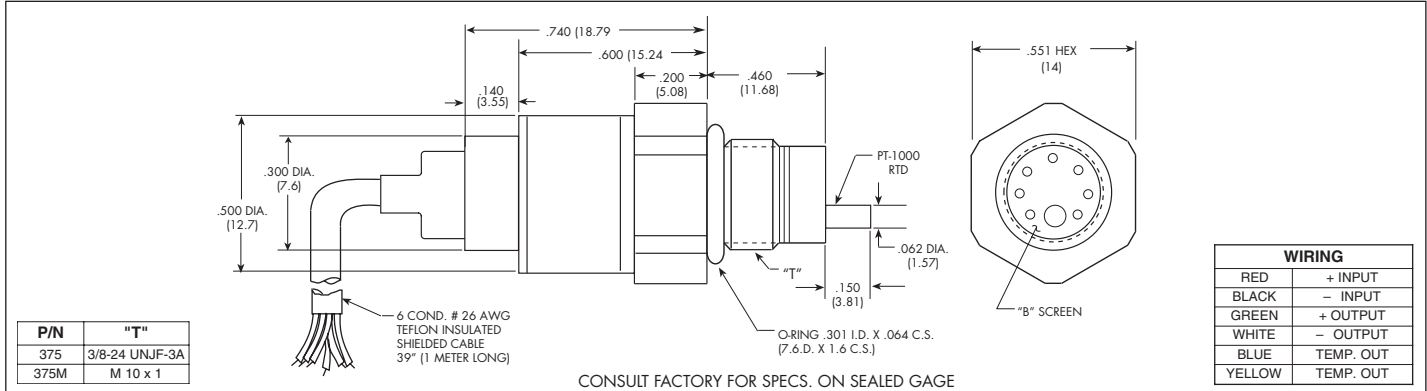

<b>INPUT</b>	1.7	3.5	7	17	35	70	170 BAR
Pressure Range	25	50	100	250	500	1000	2500 PSI
Operational Mode	Absolute, Sealed Gage						
Over Pressure	3.5	7	14	35	52	105	210 BAR
	50	100	200	500	750	1500	3000 PSI
Burst Pressure	3 Times Rated Pressure						
Pressure Media	All Nonconductive, Noncorrosive Liquids or Gases (Most Conductive Liquids and Gases - Please Consult Factory)						
Rated Electrical Excitation	10 VDC						
Maximum Electrical Excitation	15 VDC						
Input Impedance	1000 Ohms (Min.)						
<b>OUTPUT</b>	1000 Ohms (Nom.)						
Output Impedance	1000 Ohms (Nom.)						
Full Scale Output (FSO)	100 mV (Nom.)						
RTD	1000 Ohms Platinum, DIN EN 60751 Tables (65% Response Time 3 Seconds Max.)						
Residual Unbalance	± 5 mV (Typ.)						
Combined Non-Linearity, Hysteresis and Repeatability	± 0.1% BFSL (Typ.), ± 0.5% BFSL (Max.)						
Resolution	Infinitesimal						
Natural Frequency (KHz) (Typ.)	240	300	380	550	700	1000	1400
Acceleration Sensitivity % FS/g Perpendicular	5.0x10 <sup>-4</sup>	3.0x10 <sup>-4</sup>	1.5x10 <sup>-4</sup>	1.0x10 <sup>-4</sup>	6.0x10 <sup>-5</sup>	4.0x10 <sup>-5</sup>	2.5x10 <sup>-5</sup>
Transverse	6.0x10 <sup>-5</sup>	4.0x10 <sup>-5</sup>	2.0x10 <sup>-5</sup>	1.0x10 <sup>-5</sup>	6.0x10 <sup>-6</sup>	3.0x10 <sup>-6</sup>	3.0x10 <sup>-6</sup>
Insulation Resistance	100 Megohm Min. @ 50 VDC						
<b>ENVIRONMENTAL</b>	-65°F to +350°F (-55°C to +175°C)						
Operating Temperature Range	-65°F to +350°F (-55°C to +175°C)						
Compensated Temperature Range	+80°F to +180°F (+25°C to +80°C) Any 100°F Within The Operating Range on Request						
Thermal Zero Shift	± 1% FS/100°F (Typ.)						
Thermal Sensitivity Shift	± 1% FS/100°F (Typ.)						
Steady Acceleration and Linear Vibration	100g Peak, Sine up to 5000 Hz						
Humidity	100% Relative Humidity						
Mechanical Shock	100g 11 msec. 10,000g. 100µ sec.						
<b>PHYSICAL</b>	6 Conductor 26 AWG Shielded Cable 1 Meter Long						
Electrical Connection	6 Conductor 26 AWG Shielded Cable 1 Meter Long						
Weight	12 Grams Excluding Cable						
Pressure Sensing Principle	Fully Active Four Arm Wheatstone Bridge Dielectrically Isolated Silicon on Silicon Patented Leadless Technology						
Mounting Torque	50 Inch-Pounds (Max.)						

Note: Custom pressure ranges, accuracies, mechanical configurations and RTD resistance available. Dimensions are in inches. Dimensions in parenthesis are in millimeters. Continuous development and refinement of our products may result in specification changes without notice - all dimensions nominal. (C)