

PMIS3 POSIMAG[®] Magnetic Scale Position Sensor



Very compact sensor for industrial applications Sensor head PMIS3

- Non-contact, no wear
- High velocity
- Robust shielded metal enclosure
- Protection class IP67
- Incremental encoder output A/B/Z
- Signal processing as usual with encoders
- Reference pulse and end position signal
- Indicator for velocity/position errors

A POSIMAG measuring system consists of the sensor head PMIS3 and the magnetic scale PMIB3 with the same magnetic period.

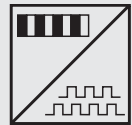

Specifications	Output	Incremental encoder output A/B with differential push-pull output, TTL/RS422 or HTL compatible							
	Excitation voltage	10 ... 30 VDC or 5 VDC ±5 %							
Excitation current	50 mA to 300 mA, depending on pulse frequency, cable length and load								
Magnetic period of the sensor	2 mm				5 mm				
Guided spacing between sensor and mag. scale (x _z)	0.1 ... 0.8 mm				0.1 ... 2 mm				
Side tracking tolerance of the sensor	±1 mm				±1 mm				
Linearity (sensor with mag. scale PMIB3)	15 µm ± 40 µm/m				30 µm ± 40 µm/m				
Repeatability	± 1 digit				± 1 digit				
Resolution with ext. times 4 counting mode [µm]	5	10	20	50	10	25	50	125	
Max. velocity with fp=50 kHz [m/s] (20 kHz: x 0.4; 10 kHz: x 0.2)	0.8	1.6	3.2	8	1.6	4	8	20	

Order code PMIS3



Model name

Magnetic period

20 = 2 mm / 50 = 5 mm

Resolution (in µm) with times 4 counting mode

Mag. period 2 mm: 5 / 10 / 20 / 50

Mag. period 5 mm: 10 / 25 / 50 / 125

Max. pulse frequency (in kHz, standard 50 kHz)

50 / 20 / 10

Output

HTL = HTL output with excitation 24 VDC, output 24 V

TTL = TTL output with excitation 5 VDC, output TTL/RS422

TTL24V = TTL output with excitation 24 VDC, output TTL/10 mA

Reference pulse/ end position signal/ status signal

Z0 = A/B w/o reference pulse / Z1 = A/B with reference pulse Z

Z2 = A/B with end position signal / *Z3 = A/B with reference pulse and status signal

(Option Z3 only for non-differential output, single ended)

Cable length (in m, standard 2 m)

Connection

S = Cable output, open end

P = Connector D-sub, 9 pin, at the cable end

Order example: **PMIS3 - 50 - 25 - 50KHZ - HTL - Z1 - 2M - S**

PMIS3 POSIMAG[®] Magnetic Scale Position Sensor



Specifications (continued)	Max. pulse frequency fp	50 kHz, 20 kHz, 10 kHz (standard 50 kHz)
	Outputs	A, \bar{A} , B, \bar{B} , reference pulse Z, \bar{Z} , end position signal E, \bar{E} , status signal ERR
	Material of enclosure	Zinc die casting
	Electrical connection	Cable 8 wire, \varnothing 5 mm, open cable end, 9 pin D-sub connector as option
	Weight (w/o cable and connector)	30 \pm 5 g
	Protection class (EN 60529)	IP67
	Environmental	
	EMC	DIN EN 61326
	Temperature	-20 ...+85°C

A POSIMAG measuring system consists of the sensor head PMIS3 and the magnetic scale PMIB3 with the same magnetic period.



The subsequent counting device must be able to process the specified maximum pulse frequency of the sensor.

Output signals	Saturation voltage	UH, UL = 0,2 V UH, UL = 0,4 V C _{last} < 10 nF	I _{out} = \pm 10 mA I _{out} = \pm 30 mA	(UH = UB - U _{out})
	Short circuit current	ISL, ISH < 800 mA ISL, ISH < 90 mA	(UH, UL = 0 V) (UH, UL = 1,5 V)	
	Rise time	t _r , t _f < 200 ns	with cable length 1 m, 10 % ... 90 %	

Pulse frequency in dependence on the cable length	Load/cable length	Load/pulse frequency fp		
		HTL single ended UB = 24 V	TTL/RS422 differential UB = 5 V *	TTL/24 V UB = 24 V
	Max. output current	50 mA	50 mA	10 mA
	R _{last} min.	500 Ω	100 Ω	500 Ω
	C _{last} max.	10 nF	10 nF	1 nF
	200 m	15 kHz	—	—
	100 m	25 kHz	100 kHz	—
	50 m	50 kHz	200 kHz	50 kHz
	10 m	100 kHz	300 kHz	100 kHz

* = note the voltage loss of the connector; excitation voltage 5 V \pm 5% of the sensor must be guaranteed

Outline drawing

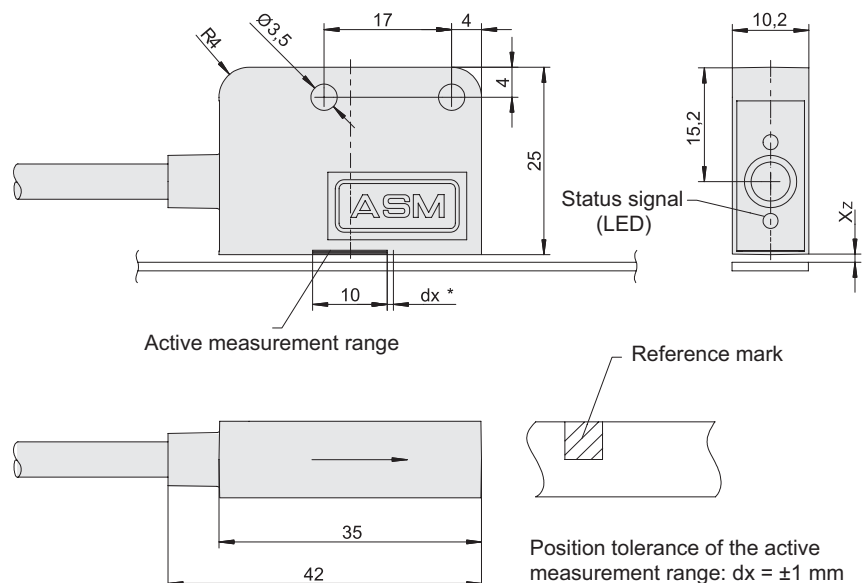

PMIS3 POSIMAG[®] Magnetic Scale Position Sensor



Output signals

Option Z1
(Reference pulse)

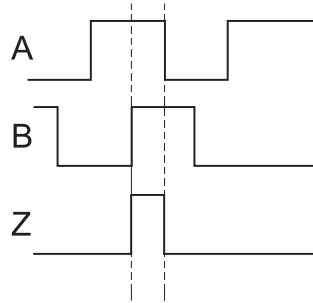

Option Z2
(End position signal)

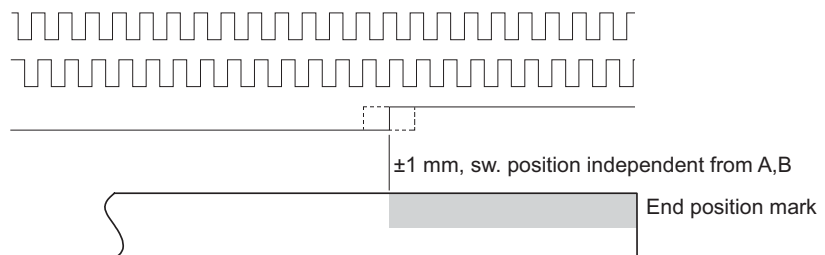

Signal wiring / connection	Signal name					Open cable end Cable colour	Conn. D-sub, 9 pin pin no.
	Option	Z0	Z1	Z2	Z3*		
Excitation +						white	1
Excitation GND (0V)						brown	5
		B	B	B	B	green	2
		A	A	A	A	yellow	3
		\overline{B}	\overline{B}	\overline{B}	ERR	grey	7
		\overline{A}	\overline{A}	\overline{A}	-	pink	6
		-	Z	\overline{E}	Z	blue	4
		-	\overline{Z}	E	-	red	8
Shield						black	9

Z = reference pulse
 E = end position signal
 ERR = status signal, periodical approx. 16 Hz, for side tracking and velocity errors
 * = status signal \overline{ERR} available only with HTL (single ended) output

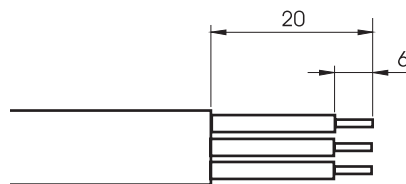

Cable output dimensions

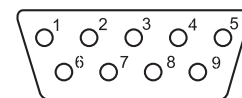

Connector D-sub (Pin)
View to connector pins

PMIB3 POSIMAG[®] Magnetic Scale

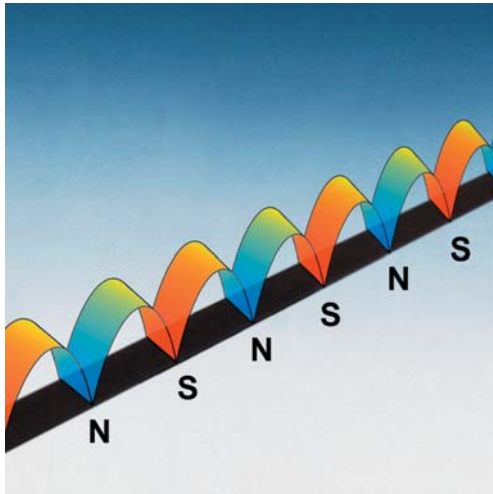

Magnetic scale PMIB3 for Position Sensor PMIS3

- Easy splicing
- Resistant to moisture and many fluids
- Extensive ruggedness against dust etc.

The magnetic material is magnetised in defined and even distances and works as a solid measure. Reference marks can be user defined in 4 mm resp. 10 mm steps. The magnetic scale retains its firmness by means of a spring steel base (standard steel strip CK 85).

Specifications		Solid measure	
		Plastic bonded flexible permanent magnet	
Base material		Spring steel CK 85	
Masking tape		Stainless steel (non magnetic)	
Measurement ranges		e.g. 100 ... 2500 mm (up to 50 m on request)	
Width		10 mm +0.1 mm / -0.2 mm	
Thickness (with masking tape)		1.7 mm ±0.1 mm	
Magnetic period		2 mm	5 mm
Linearity at 25°C	up to 30 m	±40 µm/m	±40 µm/m
	up to 50 m	±80 µm/m	±80 µm/m
Reference mark (reference pulse)		max. every 4 mm	max. every 10 mm
Measurement range		must be divisible by 4	must be divisible by 10
Linear thermal expansion coefficient		11 x 10 ⁻⁶ / K	
Operating temperature		-10 ... +70°C	

An unmagnetic masking tape made of stainless steel is available (accessories). The magnetic scale is flexible and can be glued to the surface of a cylinder with a minimum radius of 100 mm and used for angular measurements.

Order code PMIB3



Model name

Magnetic period
20 = 2 mm / 50 = 5 mm

Mounting of the magnetic scale
N = adhesive taping

Measurement range (total length = range + X mm, refer to the table on page 12)
e.g. 100, 500, 1000 ... 2500 mm (up to 50 m on request)
Measurement ranges must be divisible by 4 (resp. by 10)

Reference marks/end position marks (optional)
R1 = reference mark on the left / R2 = on the right
E1 = end position mark on the left / E2 = on the right
Additional reference marks every 4 mm (period 2 mm) resp. 10 mm (period 5 mm) from the left

Options
FP = magnetic scale in flat profile
HP = magnetic scale in high profile
AB = Masking tape (only with FP or HP)

Order example: PMIB3 - 50 - N - 1500 - R1

PMIB3-ST POSIMAG[®] Magnetic Scale

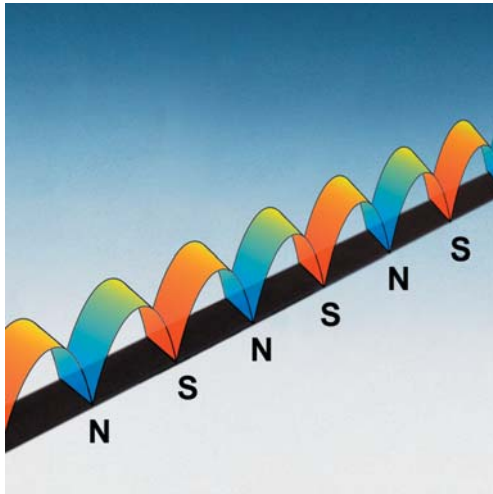

Magnetic scale PMIB3-ST for Position Sensor PMIS3

- Easy splicing
- Resistant to moisture and many fluids
- Extensive ruggedness against dust, chipping etc.
- Magnetic scale with stainless steel base

The magnetic material is magnetised in defined and even distances and works as a solid measure. Reference marks can be user defined in 4 mm resp. 10 mm steps. The magnetic scale retains its firmness by means of a spring steel base (stainless steel strip CrNi 17 7).

Specifications		Solid measure	
		Plastic bounded flexible permanent magnet	
Base material		Stainless steel CrNi 17 7 / PE	
Masking tape		Stainless steel (non magnetic)	
Measurement ranges		e.g. 100 ... 2500 mm (up to 50 m on request)	
Width		10 mm +0.1 mm / -0.2 mm	
Thickness (with masking tape)		1.7 mm ±0.1 mm	
Magnetic period		2 mm	5 mm
Linearity at 25°C	up to 30 m	±40 µm/m	±40 µm/m
	up to 50 m	±80 µm/m	±80 µm/m
Reference mark (zero pulse)		max. every 4 mm	max. every 10 mm
Measurement range		must be divisible by 4	must be divisible by 10
Linear thermal expansion coefficient		11 x 10 ⁻⁶ / K	
Operation temperature		-10 ... +70°C	

An unmagnetic masking tape made of stainless steel is available (accessories). The magnetic scale is flexible and can be glued to the surface of a cylinder with a minimum radius of 100 mm and used for angular measurements.

Order code PMIB3-ST

PMIB3-ST — [] — [] — [] — [] — []

Model name

Magnetic period

20 = 2 mm / 50 = 5 mm

Mounting of the magnetic scale

N = adhesive taping

Measurement range (total length = range + X mm, refer to the table on page 12)

e.g. 100, 500, 1000 ... 2500 mm (up to 50 m on request)

Measurement ranges must be divisible by 4 (resp. by 10)

Reference marks/end position marks (optional)

R1 = reference mark on the left / R2 = on the right

E1 = end position mark on the left / E2 = on the right

Additional reference marks every 4 mm (period 2 mm) resp. 10 mm (period 5 mm) from the left

Options

FP = magnetic scale in flat profile

HP = magnetic scale in high profile

AB = masking tape (only with FP or HP)

Order example: PMIB3-ST - 50 - N - 1500 - R1

PMIB3-HT POSIMAG[®] Magnetic Scale

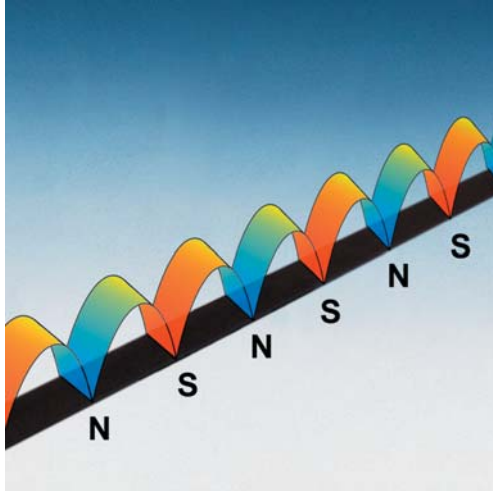

Magnetic scale PMIB3-HT for Position Sensor PMIS3

- Easy splicing
- Resistant to moisture and many fluids
- Extensive ruggedness against dust etc.
- High temperature durability
- Magnetic scale with stainless steel base

The magnetic material is magnetised in defined and even distances and works as a solid measure. Reference marks can be user defined in 4 mm resp. 10 mm steps. The magnetic scale retains its firmness by means of a spring steel base (stainless steel strip CrNi 17 7).

Specifications		Solid measure	
		Plastic bonded flexible permanent magnet	
Base material		Stainless steel CrNi 17 7 / elastomer	
Masking tape		Stainless steel (non magnetic)	
Measurement ranges		e.g. 100 ... 2500 mm (up to 50 m on request)	
Width		10 mm +0.1 mm / -0.2 mm	
Thickness (with masking tape)		1.7 mm ±0.1 mm	
Magnetic period		2 mm	5 mm
Linearity at 25°C	up to 30 m	±40 µm/m	±40 µm/m
	up to 50 m	±80 µm/m	±80 µm/m
Reference mark (reference pulse)		max. every 4 mm	max. every 10 mm
Measurement range		must be divisible by 4	must be divisible by 10
Linear thermal expansion coefficient		11 x 10 ⁻⁶ / K	
Operating temperature		-20 ... +120°C	

An unmagnetic masking tape made of stainless steel is available (accessories). The magnetic scale is flexible and can be glued to the surface of a cylinder with a minimum radius of 100 mm and used for angular measurements.

Order code PMIB3-HT

PMIB3-HT - [] - [] - [] - [] - []

Model name

Magnetic period

20 = 2 mm / 50 = 5 mm

Mounting of the magnetic scale

N = adhesive taping

Measurement range (total length = range + X mm, refer to the table on page 12)

e.g. 100, 500, 1000 ... 2500 mm (up to 50 m on request)

Measurement ranges must be divisible by 4 (resp. by 10)

Reference marks/end position marks (optional)

R1 = reference mark on the left / R2 = on the right

E1 = end position mark on the left / E2 = on the right

Additional reference marks every 4 mm (period 2 mm) resp. 10 mm (period 5 mm) from the left

Options

FP = magnetic scale in flat profile

HP = magnetic scale in high profile

AB = masking tape (only with FP + HP)

Order example: PMIB3-HT - 50 - N - 1500 - R1

PMIS3/ PMIB3/-HT/-ST POSIMAG® Magnetic Scale



**Position of the
standard
reference
marks**

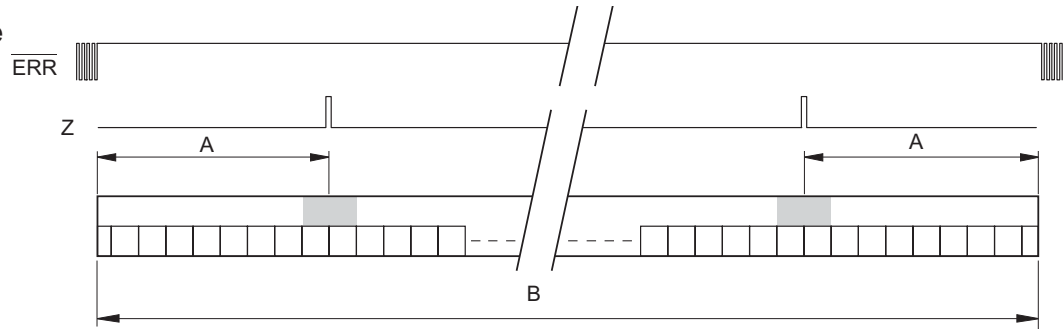

Dimensions reference	Magnetic period	Switching position A	Total length B
	2 mm	20.0 ±1 mm	measurement range + 40 mm
	5 mm		
	2 mm with high profile	60.0 ±1 mm	measurement range + 120 mm
	5 mm with high profile		

Additional reference marks every 4 mm (period 2 mm) resp. 10 mm (period 5 mm) from the left h. s.

**Position of the
end position
marks**

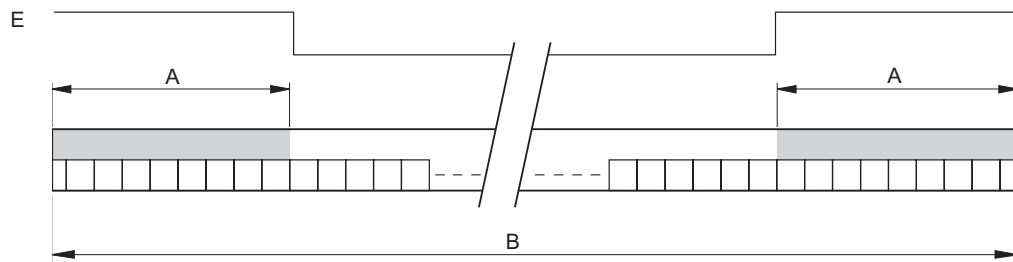

Dimensions end positions	Magnetic period	Switching position A	Total length B
	2 mm	21.0 ±1 mm	measurement range + 50 mm
	5 mm	22.5 ±1 mm	measurement range + 50 mm
	2 mm with high profile	61.0 ±1 mm	measurement range + 130 mm
	5 mm with high profile	62.5 ±1 mm	measurement range + 130 mm

PMIS3/ PMIB3/-HT/-ST POSIMAG®

Magnetostrictive Position Sensor

Accessories



Masking tape PMAB:

Masking tape made of stainless steel for POSIMAG magnetic scale PMIB3, width 10 mm, thickness 0.2 mm

Order code: **PMAB** — **10MM** —
 Length in mm

Outline drawing flat profile PMFP

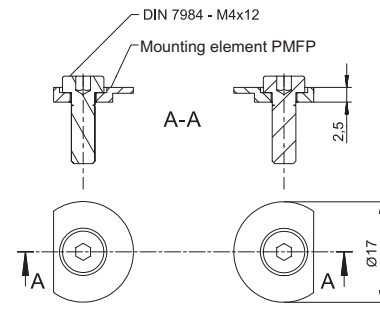
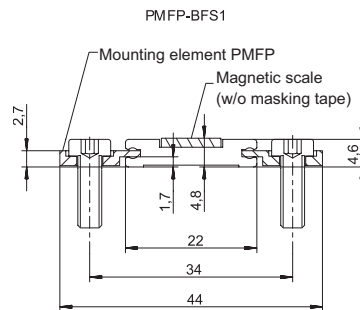

Mounting set PMFP-BFS1

Outline drawing high profile PMHP

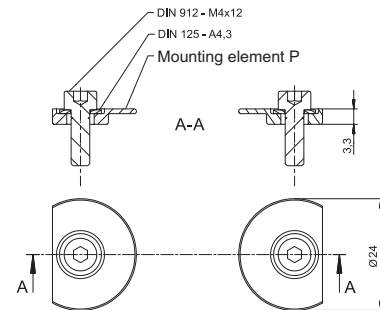
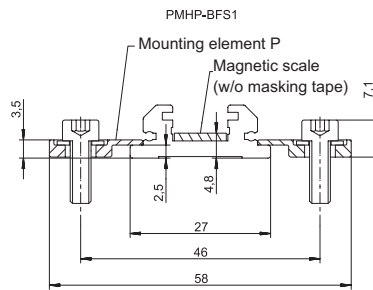

Mounting set PMHP-BFS1

Slider for high profile PMGW3

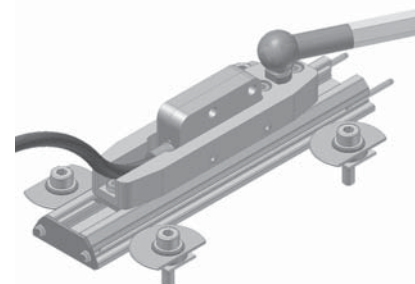
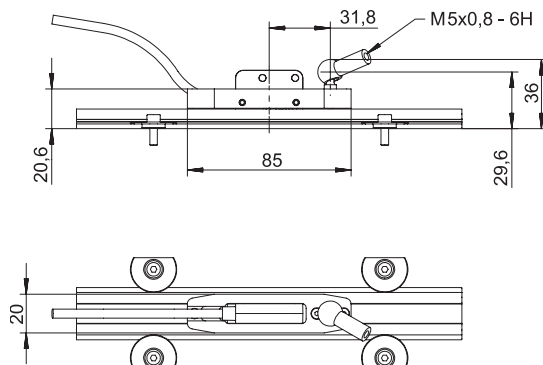

Dimensions informative only. For guaranteed dimensions consult factory.

PMIB3/-HT/-ST POSIMAG® Magnetic Scales – overview



Magnetic Scales – Technical Information

Types of magnetic scales / Application recommendation

Type	Standard scale PMIB3	Stainless steel scale PMIB3-ST	Stainless steel elastomer scale PMIB3-HT
base strip	CK 85 stainless steel	CrNi 17 7 stainless steel	CrNi 17 7 stainless steel
magnetic scale	PE magnetic scale	PE magnetic scale	Elastomer magnetic scale
environmental conditions	normal	difficult	very difficult
corrosion resistance	normal	high	high
temperature resistance	normal	normal	high
media resistance	normal	normal	high

Chemical durability – PE magnetic scales (PMIB3, PMIB3-ST)

no / little influence	weak / middle influence	strong influence
some mineral oils vegetable oils methyl / isopropanol weak organic acids formaldehyde	anhydrous ammonia acetylene benzin kerosene steam, vapour acetic acid 20% / 30% sea water olein acid	benzene nitrobenzene paint solvents turpentine nitric acid 70% hydrochloric acid 37% toluene xylene tetrachloromethane trichloroethylene

Chemical durability – Elastomer magnetic scales (PMIB3-HT)

no / little influence	weak / middle influence	strong influence
motor oils gear oils ATF (automatic transmission fluid) hydraulic fluid kerosene antifreeze agent purifying agent turpentine water sea water/salt water	JP-4 fuel (Jet fuel) gasoline/petrol heptane alcohol	aromatic hydrocarbon (benzene, toluene, xylene) ketone anorganic acids (HCl, H ₂ SO ₄)