

POSIROT®
PMIS4, PMIR4
Magnetic incremental encoder

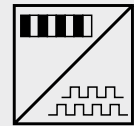

Magnetic wheels for rotative applications with POSIROT® position sensor PMIS4

- All metal housing
- Protection class IP67
- Highest EMC protection
- Large guiding distance of ± 1 mm
- Suitable for harsh environments
- Up to 184,320 pulses/360°



Order Code PMIR4
(magnetic wheel)

PMIR4 - [] - [] - [] - []

Model name

Magnetic period

20 = 2 mm

Number of Poles

50 / 64 / 90 (other pole numbers on request)

Z signal mark

O = without / M = with

Inner diameter

20 = 20H7 (other diameters on request)

Order Code PMIS4
(sensor head)

PMIS4 - [] - [] - [] KHZ - [] - [] - [] M - []

Model name

Magnetic period

20 = 2 mm

Scaling factor

See table page 37

Maximum pulse frequency (in kHz, standard 50 kHz)

50 / 20 / 10 (other frequencies on request, max. 480 kHz)

Output

HTL = HTL output with excitation 24 V DC, output 24 V

TTL = TTL output with excitation 5 V DC, output TTL/RS-422

TTL24V = TTL output with excitation 24 V DC, output TTL/10 mA

Signal Z / status signal

Z0 = A/B w/o signal Z

Z1 = A/B with signal Z

Z3 = A/B with signal Z and status signal, only for non-differential (single-ended) outputs

Cable length (in m, standard 2 m)

Connection

S = Open cable end

P15 = D-Sub connector at the cable end, 15 poles

Order example magnetic wheel: PMIR4 - 20 - 50 - O - 20

Order example sensor: PMIS4 - 20 - 100 - 50KHZ - HTL - Z0 - 2M - S

POSIROT® PMIS4 Magnetic incremental encoder



Specifications	Output	Incremental encoder output A/B with differential push-pull output, TTL/24 V-, TTL/RS-422- or HTL-compatible	
	Excitation voltage	10 ... 30 V DC or 5 V DC ±5 %	
	Excitation current	50 mA to 300 mA, depending on pulse frequency, cable length and load	
	Magnetic period of the sensor	2 mm	5 mm
	Guided spacing between sensor and wheel x_z	0,1 ... 0,8 mm	0,1 ... 2 mm
	Side tracking tolerance of the sensor	±1 mm	±1 mm
	Linearity (sensor with magnetic wheel PMIR4)	±0.1°	±0.1°
	Repeatability	±1 digit	±1 digit
	Maximum pulse frequency f_p	50, 20, 10 kHz (standard 50 kHz, max. 480 kHz)	
	Output signals	A, \bar{A} , B, \bar{B} , signal Z, \bar{Z} , status signal \bar{ERR}	
	Material of housing	Zinc die casting	
	Connection	Cable 8 wire, dia. 5 mm, open cable end. 15 pin D-Sub conn. at the cable end as option. Max. length of the integrated sensor cable: output TTL: 3 m; HTL/TTL24V: 20 m	
	Weight (w/o cable and connector)	30 ±5 g	
	Protection class (EN 60529)	IP67	
	Environmental		
EMC	DIN EN 61326		
Temperature	-40 ... +85 °C (-40 ... +185 °F)		



The subsequent counting device must be able to process the specified maximum pulse frequency of the sensor.

Output signals	Saturation voltage	U _H , U _L = 0.2 V U _H , U _L = 0.4 V C _{last} < 10 nF	I _{out} = ±10 mA (U _H = U _B - U _{out}) I _{out} = ±30 mA
	Short circuit current	ISL, ISH < 800 mA ISL, ISH < 90 mA	(U _H , U _L = 0 V) (U _H , U _L = 1.5 V)
	Rise time	t _r , t _f < 200 ns	with cable length 1 m, 10 % ... 90 %

Pulse frequency in dependence on the cable length	Load/cable length	Load/pulse frequency f_p		
		HTL single ended UB = 24 V	TTL/RS422 differential UB = 5 V *	TTL/24 V UB = 24 V
	Max. output current	50 mA	50 mA	10 mA
	R _{last} min.	500 Ω	100 Ω	500 Ω
	C _{last} max.	10 nF	10 nF	1 nF
	200 m	15 kHz	—	—
	100 m	25 kHz	100 kHz	—
	50 m	50 kHz	200 kHz	50 kHz
	10 m	100 kHz	300 kHz	100 kHz

* = consider the voltage loss of the cable; the excitation voltage 5 V ± 5% of the sensor must be guaranteed.

Note: For longer distances (see specification above) you must use min. 0.5 mm² wire for „Excitation+“ and „Excitation GND“ (see signal wiring next page), all signal wires must be min. 0.14 mm²!

POSIROT®
PMIS4, PMIR4
Magnetic incremental encoder



Outline drawing

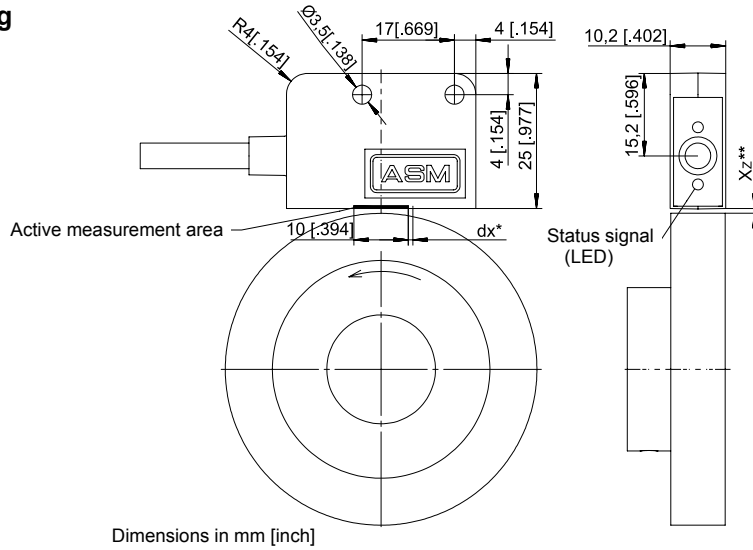

Dimensions in mm [inch]

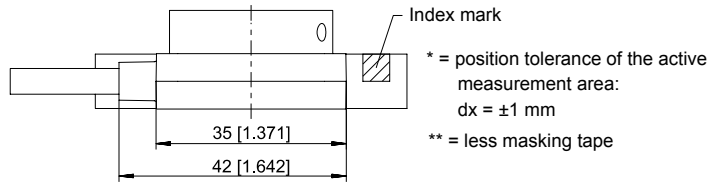

Output signals

Option Z1 (signal Z)

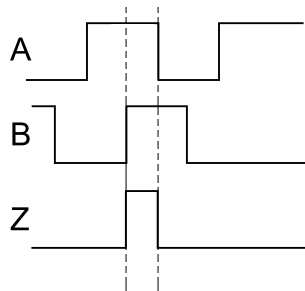

Signal wiring	Signal name			Cable with open end, cable color	Connector D-Sub, pin no. 15 poles
	Option	Z0	Z1		
				white	1
				brown	2
		B	B	green	6
		A	A	yellow	4
		\bar{B}	\bar{B}	grey	7
		\bar{A}	\bar{A}	pink	5
		-	Z	blue	8
		-	\bar{Z}	red	9
				black	12

Z = reference pulse
 ERR = status signal, periodical approx. 16 Hz, for side tracking and velocity errors
 * = status signal ERR available only with HTL (single ended) output

Connection

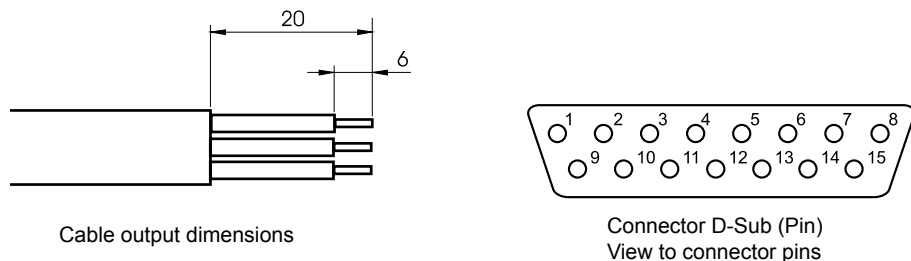

Cable output dimensions

Connector D-Sub (Pin)
View to connector pins

POSIROT® PMIR4 Incremental magnetic wheels



Specification	Material	Plastic bonded magnetic material or magnetic scale
	Base material	Aluminium
	Signal periods per revolution	From 50 poles/revolution
	Magnetic period	2 mm
	Temperature range	-40 ... +85°C (-40 ... +185 °F)
	Linearity with sensor PMIS4	Approx. ± 0.1°

Data valid in connection with the sensor PMIS4.

Standard magnetic wheels

Type	Poles	∅	Height	Signal periods/rotation	Inside diameter
PMIR4-20-50	50	31.8	18	decade division (refer to the table below)	20H7
PMIR4-20-64	64	40.7	18	binary division (refer to the table below)	20H7
PMIR4-20-90	90	57.3	18	vernier (refer to the table below)	20H7

Further pole numbers, diameters and magnetic periods on request.

Scaling factor Sensor PMIS4-20- ...	PMIR4-20-50		PMIR4-20-64		PMIR4-20-90	
	Signal periods	R.p.m.)* (at 480 kHz)	Signal periods	R.p.m.)* (at 480 kHz)	Signal periods	R.p.m.)* (at 480 kHz)
1	50	6000	64	6000	90	6000
2	100	6000	128	6000	180	6000
4	200	6000	256	6000	360	6000
8	400	6000	512	6000	720	6000
10	500	5760	640	4500	900	3200
16	800	6000	1024	6000	1440	6000
20	1000	5760	1280	4500	1800	3200
25	1250	6000	1600	6000	2250	5120
32	1600	6000	2048	6000	2880	6000
40	2000	5760	2560	4500	3600	3200
50	2500	6000	3200	6000	4500	5120
64	3200	6000	4096	5625	5760	4000
80	4000	5760	5120	4500	7200	3200
100	5000	4608	6400	3600	9000	2560
125	6250	3686	8000	2880	11 250	2048
128	6400	3600	8192	2813	11 520	2000
200	10 000	2304	12 800	1800	18 000	1280
250	12 500	1843	16 000	1440	22 500	1024
256	12 800	1800	16 384	1406	23 040	1000
400	20 000	1152	25 600	900	36 000	640
500	25 000	922	32 000	720	45 000	512
512	25 600	900	32 768	703	46 080	500
1024	51 200	450	65 536	352	92 160	250
2048	102 400	225	131 072	176	184 320	125

)* Maximum revolution per minute mechanically 6.000 R.p.m.

Outline drawings

PMIR4-20-50

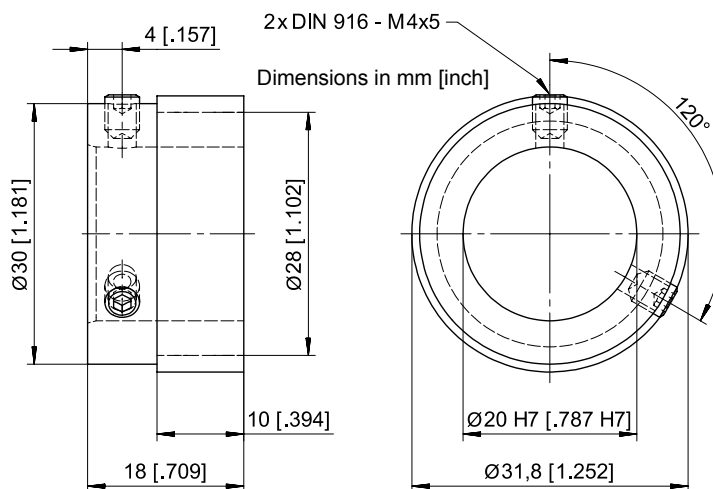

PMIR4-20-64

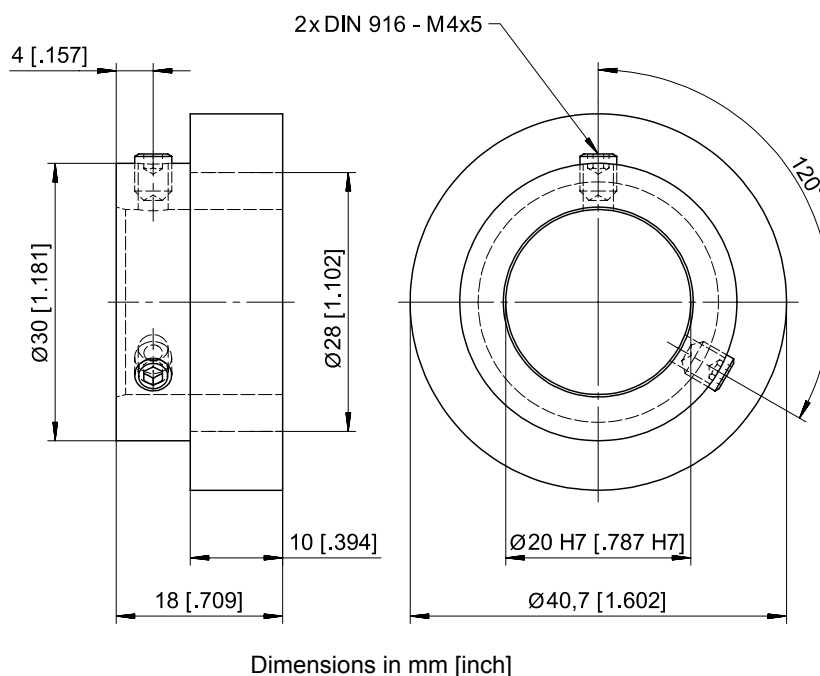

Dimensions informative only.
 For guaranteed dimensions
 please consult factory.

POSIROT®
PMIR4 / PMIR5
Incremental magnetic wheels



Outline drawings

PMIR4-20-90

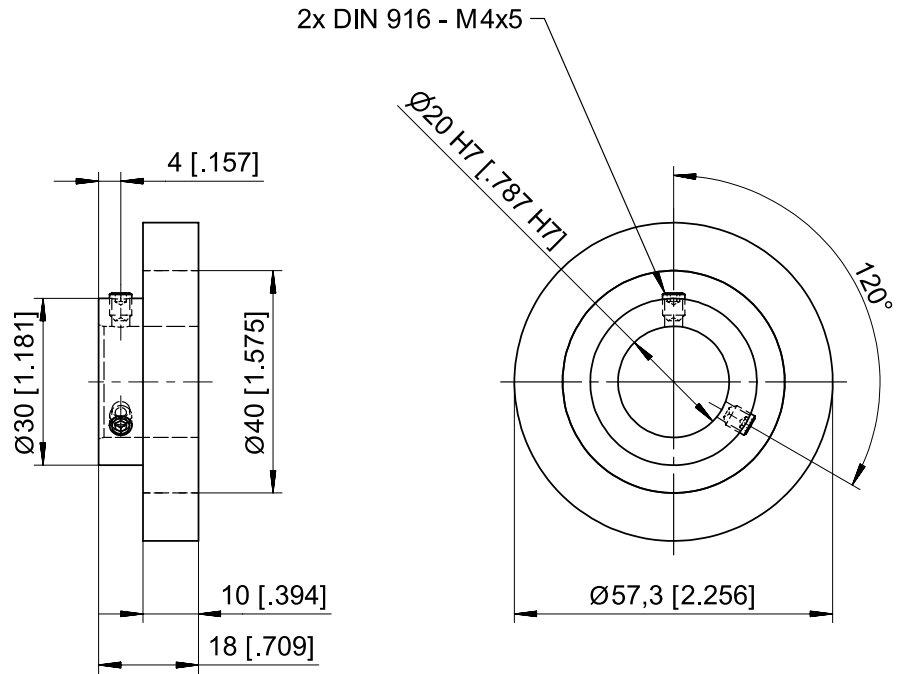

Dimensions in mm [inch]

PMIR5-50-64

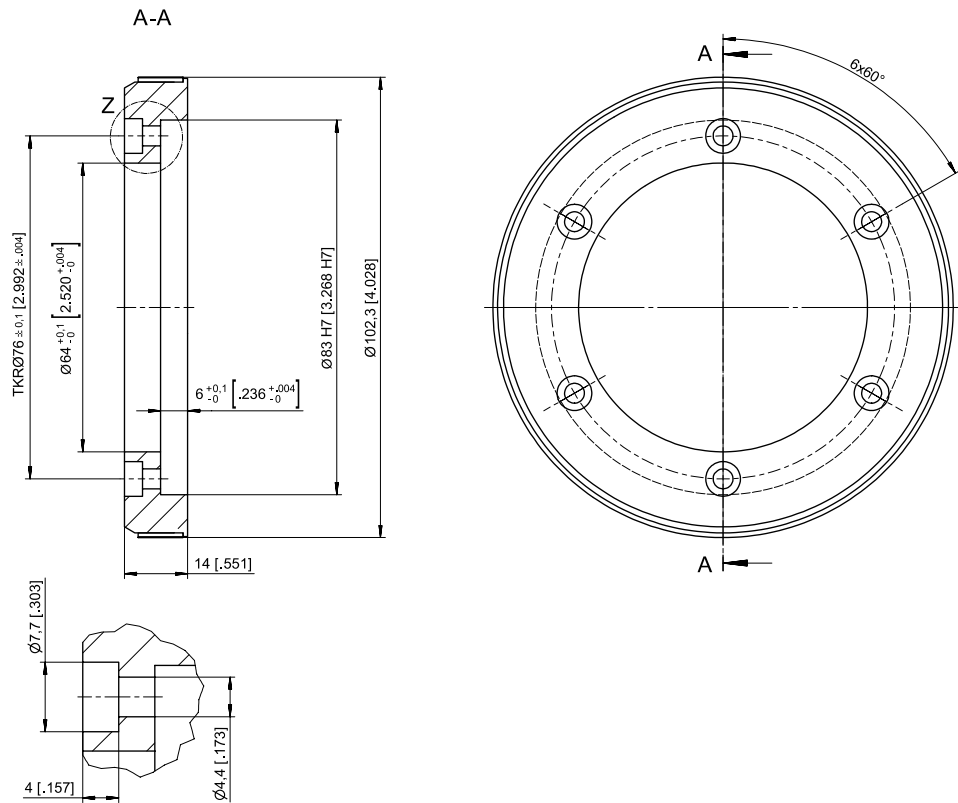

Dimensions informative only.
 For guaranteed dimensions please consult factory.