

JAQUET T600 MULTITASKER
 SIL 2 CERTIFIED, MULTICHANNEL
 MEASUREMENT AND MONITORING
 INSTRUMENT FOR COMPLEX AND
 DEMANDING MACHINE PROTECTION
 APPLICATIONS.
 REMOTE DISPLAY AS OPTION.

JAQUET T600 MultiTasker - a measurement & monitoring instrument with 2 frequency and 1 analog inputs

FEATURES

- High accuracy speed measurement: 0.002% for limits and 0.1% referenced to 20 mA
- 2 frequency + 1 analog + 2 binary inputs
- Direction and creep detection
- Temperature measurement with PT100
- 2 current, 4 relay and 2 Open Collector outputs
- Sensor monitoring for all sensor technologies
- Ethernet interface - configuration via Windows software
- Extensive parameter and limit setting possibilities
- Programmable logical, diagnostic and measurement functions
- Plug in terminals

THE T600 ADVANTAGE

- Fast 8 ms reaction time on overspeed
- 4 parameter sets each with 6 System Limits for almost limitless applications
- Logical limit combinations save relays & wiring
- Acceleration measurement
- Compatible with all popular sensor types
- SIL 2 (IEC 61508) as an option - GL approval for marine use

TYPICAL APPLICATIONS

- Micro turbine speed measurement and overspeed protection
- Diesel engine start control and protection
- Dual turbocharger speed measurement
- Equipment in safety critical applications
- Universal tachometer

2 Channel Tachometer with 4 Relays, 2 Open Collector and two 0/4-20mA Outputs:

Type and part numbers	AC version: T601.50	part number: 384Z-05602
	DC version: T601.10	part number: 384Z-05603
	AC version SIL2 & KTA: T601.51	part number: tbd
	DC version SIL2 & KTA: T601.11	part number: tbd
Technical Data		
Measurement time	Configurable min. measurement time (t_M): 2/5/10/20/50/100/200/500 ms, 1/2/5s.	
Reaction time	Current output: Typical $t_M + 4.1$ ms	Maximum Input period + $t_M + 4.1$ ms
	Relays: Typical $t_M + 6$ ms	Maximum Input period + $t_M + 6$ ms
Accuracy		
Limits	Frequency: 0.002%	
	Current: 0.025%	
	Temperature: 0.5%	
Current output	0.1% referenced to 20mA or the end value Max 0.20 % from measuring value + 2 LSB (-40°...+70°C)	
Sensor inputs (2)	To measure frequency signals (speed sensors)	
Frequency range	0.025 Hz to 50 kHz	
Input impedance	> 11.5 kOhm	
Trigger levels	Selectable by software:	fixed at 3 V or adaptive from either 20 mVrms or 180 mVrms
Sensor supply	+14 V \pm 0.5 V, max 35 mA, short circuit proof	
Internal Pull Up	1 kOhm for connecting active 2 wire or NAMUR sensors to +14 V	
Sensor monitoring	3 wire sensors:	programmable current consumption limits of 0.5...35mA.
	Electromagnetic sensors:	Open circuit detection
Analysis functions	Creep Direction Math (e.g. subtraction, percentage, acceleration, variance)	
Analog input (1)	To measure current or temperature	
Type	0...20 mA / 4...20 mA / PT100 for temperature	
Driving voltage (active input)	Min. 12 V	Max. 14 V
External load (active input)	Max. 600 Ohm	
Input impedance (passive input)	50 Ohm	
Resolution	10 bit corresponding to 1:1024	
Analysis functions	Math (e.g. acceleration, variance)	
Binary inputs (2)	Isolated inputs for binary signals	
Levels	Low: < +5 V	High: > +15 V (software selection of active Low or High)
Functions	External selection of controls (parameter sets) Combination in System Limit Reset for relay, creep and memory	
Data I/O		
Configuration and monitoring	Ethernet interface	
Controlling and monitoring	CAN	
Supply	AC version: 90...264 VAC max 14 W	
	DC version: 18...36 VDC max 6.8 W	
Relays (4)	To treat the status of System Limits and sensor	
Limits	4 parameter sets each with 6 System Limits (AND / OR combined values)	
Hysteresis	Freely programmable upper and lower set-points for each limit	
Function	Latching / inversion (fail safe)	
Contacts	Change-over: 230 VAC / max. 0.45 A 125 VAC / max. 1 A 30 VDC / max. 2 A	

Open Collector outputs (2)

Function
Contacts

Isolated outputs of sensor frequencies: programmable x1, x2 or x4 (subject to 2 channel phase shift). Can also react on System Limits, see above.
Latching / inversion (fail safe)
Umax = 36 Vdc Imax = 30 mA

Analog outputs (2)

Range
Type
Maximum load
Resolution
Maximum linearity error

Isolated current output to treat information of sensor 1, 2, analog in or of the math result.
From - 99999 to + 999999 free programmable start and end value
0...20 mA / 4...20 mA
500 Ohm corresponding to a maximum of 10 V
14 bit corresponding to 1:16384 (actual resolution: 1.36 µA)
0.015 %

Memory

Max/min values
Event memory
Security event memory

To store important values
Sensor 1, sensor 2, analog in
About 100 values of all status changes stored in either ring buffer or limited memory
100 measurements before and after the security event are stored with date and time

Operating temperature

AC Version: -25°...+50°C
DC Version: -40°...+70°C

Storage temperature

-40°...+85°C

Climatic immunity

In accordance with DIN 40 040

Relative humidity

75% averaged over 1 year; up to 90% for 30 days max.

Isolation

Min. 1000 V

EMC

Emissions in accordance with international standards and EN 50081-2.

Immunity to EN 50082-2

Conducted emissions: CISPR 16-1, 16-2

Radiated emissions: EN 55011

Electrostatic discharge: IEC 61000-4-2

Electromagnetic fields: IEC 61000-4-3

Fast transients: IEC 61000-4-4

Slow transients: IEC 61000-4-5

RF common mode: IEC 61000-4-6

Pulse mode electric field: ENV 50140

Magnetic fields: IEC 1000-4-8

Other standards

GL / Germanischer Lloyd

SIL 2 IEC 61508

Dimensions

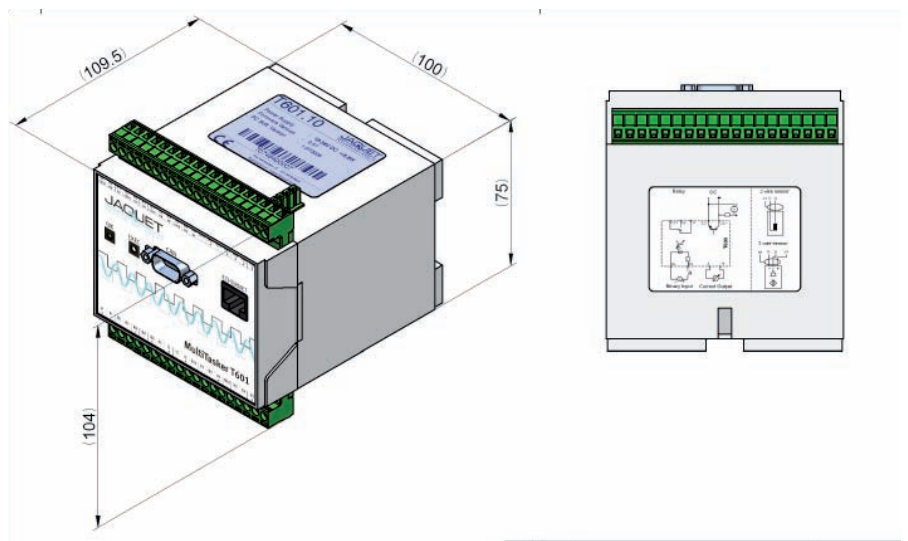

Mounting

DIN-rail DIN 4622713 (EN 50022) or mounting plate DIN 43660 (46121)

Housing

Material ABS, color RAL 7035

Terminals

Plug-in style

Weight

AC version: 425 g

DC version: 396 g

Limits for limitless applications

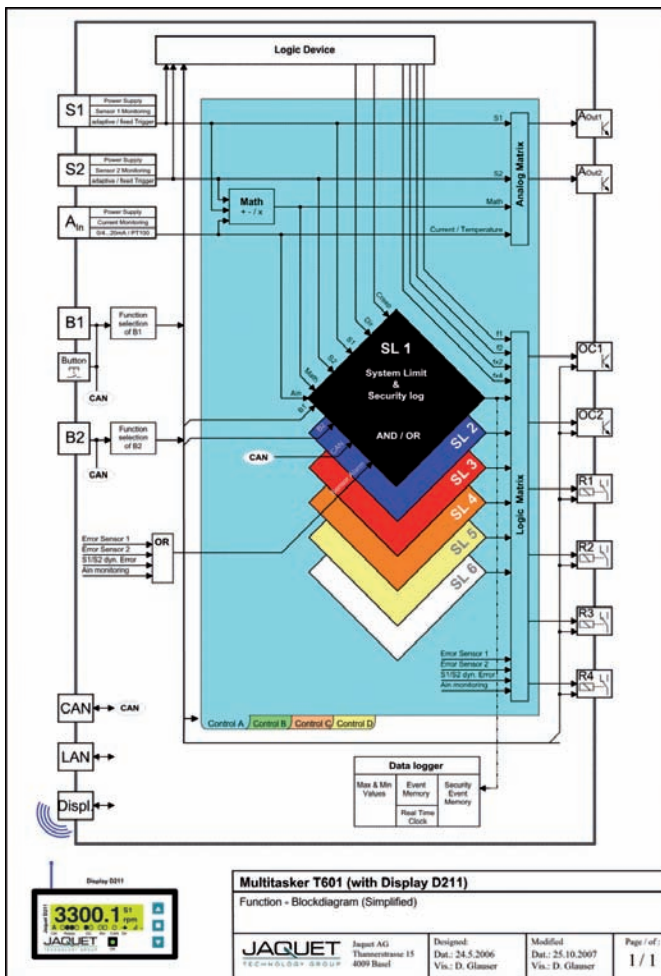

T600's allow you the freedom to choose the functions or system configuration that best match your application.

As well as being replacements for previous generation tachometers they can process multiple sensors data including frequency, 0/4...20mA analog, a directly connected PT100 temperature resistor, binary inputs & sensors with CAN interface.

T600 takes T500 to a higher level. The 2 frequency inputs may either be interpreted as speed data or speed and timing signal. Logic analyses and mathematic calculations expand the possibilities.

Want to know when a trip occurred? Could you use more gear teeth than space allows? Need to swap between different parameter sets? - No problem - the T600 MultiTasker provides the solution.

Uniquely, the T600's also enable you to logically combine decision parameters from more than one sensor or command to create control signals.

System Limits for simple configuration of complex solutions

Jaquet Technology Group - Online - T601 - Config user

Systemlimit 1	Systemlimit 2	Systemlimit 3	Systemlimit 4	Systemlimit 5	Systemlimit 6
Sensor 1	Sensor 2	Analog input	Math function	Creep	Direction
Limit high: 300.0	Limit high: 300.0	Limit high: 66.0	Limit high: 10.0	<input checked="" type="radio"/> Creep	<input checked="" type="radio"/> CW
Limit low: 290.0	Limit low: 290.0	Limit low: 60.0	Limit low: 5.0	<input type="radio"/> no Creep	<input checked="" type="radio"/> CCW
<input checked="" type="radio"/> Overspeed	<input checked="" type="radio"/> Overspeed	<input checked="" type="radio"/> Over-run	<input checked="" type="radio"/> Over-run	<input type="radio"/> active	<input checked="" type="radio"/> active
<input type="radio"/> Underspeed	<input type="radio"/> Underspeed	<input type="radio"/> Under-run	<input type="radio"/> Under-run	<input type="radio"/> inactive	<input type="radio"/> inactive
Logic: <input type="radio"/> OR <input checked="" type="radio"/> AND					
Sensoralarm: <input checked="" type="checkbox"/> OR					

Jaquet Technology Group - Online - T601 - Config user

Actual input data	Status	Actual output value
Speed value: 33.3308	Active control: Control A	Analog output 1: 4.680 mA
Sensor 2: 100005	System limits: Systemlimit 1: active, Systemlimit 2: active, Systemlimit 3: inactive, Systemlimit 4: inactive	Analog output 2: 12.00 mA
Analog input: Temperature [°C]: 23.4000		Relay status: Relay 1: energised, Relay 2: energised
Math value:		

Don't lose time by thinking about parallel- and serial wiring, inverting and double inverting of signals just to get that signal you need. Only think about what signal you finally need and define a System Limit.

As shown in the example beside: Needing a TRIP as soon as machine turns clockwise faster as 300 rpm while the temperature is still not at working temperature (temperature of 60°C measured on the analog input).

After that assign this System Limit to a relay and define its behaviour.

T600 configuration

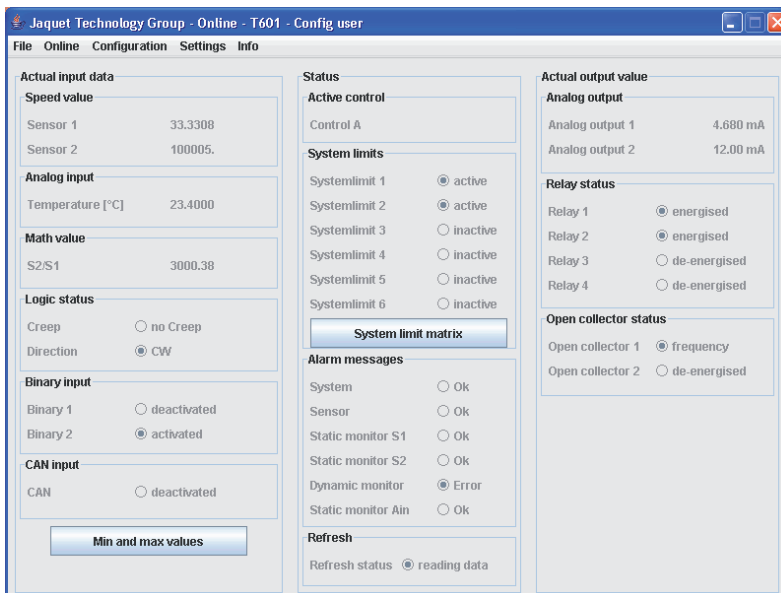

The configuration software is stored in the T600 itself. So you never have to think about software version - it will always work with the firmware.

The software allows:

- Fast and user friendly parameter set up.
- Access to stored parameters.
- Normal file handling and printing of parameter details
- PC display of measurement, relay and alarm status.
- Password protection with 3 levels

All you need is an Ethernet terminal, a crossed Ethernet cable (not included) and an internet browser (no internet access needed).

Display D211 (optional)

To display measured and calculated values of the T600 Multitasker. A special mode allows you also to display the status of the binary in- and outputs. The displayed values are selected with the buttons on front panel.

A LED indicates the status of the T600.

Blue tooth version

The communication goes over blue tooth®. One Bluetooth Master B600 has to be connected to the T600. After that up to 7 displays D211.11 can be used to display independently different values of that T600 Multitasker.

Type and part numbers

Bluetooth version: D211.11 384Z-05730
 Bluetooth Master: 600.11 387Z-05731

Technical Data

Type: 5 digits LCD
 Range: -99'999...999'999
 Format: Auto range or defined dot position
 Displayed values: All input values, math values and current output values incl. unit
 Displayed status: Active control, relays, open collectors, binary inputs, CAN
 Mounting: Separate unit for front panel mounting
 Dimensions: 95 x 48 x 86mm
 Blue tooth: Class 1 (100 m in open field)
 Power Supply: 18...36 VDC



Cable version

The Display is connected to the T600 Multitasker by cable. Communication and power goes over this cable.

Type and part number:

Display: D211.10 384Z-05729

Please note: Information is subject to change. For more technical information please refer to operating instructions.

JAUQUET TECHNOLOGY GROUP offers the world's most versatile and advanced range of solutions for the detection, measurement, diagnosis and management of rotational speed.

Our industry and application specific expertise ensures that you will achieve an optimum solution. Completely matched to your individual requirements, meeting key industrial standards and certifications, our products help boost the performance of your machinery while reducing cost of ownership.

TYPICAL INDUSTRIES SERVED

- Automotive and truck
- Diesel / Gas engines
- Hydraulics
- Railway
- Turbines
- Turbochargers
- Industrial machinery

PRODUCTS – SPEED SENSORS

- Various technologies
- Standard, custom and OEM models
- For demanding applications, e.g. 300,000 rpm, temperature up to 320 °C / 600 °F, high vibration, shock to 200 g, etc.
- GreenLine speed sensors for general applications
- Ex models for hazardous areas
- Pole bands and target wheels available where needed

PRODUCTS – SYSTEMS

- Multi-channel overspeed protection systems
- 1–2 channel measurement, protection and control modules
- Engine diagnostic systems
- Redundant speed measurement and indication

SPECIAL PROJECT EXAMPLES

- An automotive linear movement sensor
- Integrated power and torque measurement for display and gearbox control
- Naval spec. turbine protection for nuclear submarines
- Speed measurement in turreted, tracked vehicles

QUALITY MANAGEMENT AND STANDARDS

- Quality management: TS 16949 and ISO 9001, ZELM ATEX 1020, KWU
- Sensors: GL, KWU, TÜV, ATEX, EN 50155, NF F 16-101 102, ABS, EMC
- Systems: IEC 61508 SIL 2 and SIL 3, API 670, GL, TÜV, KWU, EX
- Environmental: RoHs - EU directive 2002/95/EC

JAUQUET – YOUR PARTNER

- Efficient and professional service - JAUQUET TECHNOLOGY GROUP is headquartered in Basel, Switzerland and has subsidiaries in Belgium, China, Germany, the Netherlands, United Kingdom and United States along with a worldwide distributor and end-user service network.
- Flexible production quantities; from 1 to millions per project
- Reduction of total costs by intelligent and cost-effective solutions
- Fast turn around time